

-
- ▶ Handling
Machining
Assembly
Organisation

FESTO

-
- ▶ Pneumatics
Electronics
Mechanics
Sensorics
Software

Hesse

99 Examples of Pneumatic Applications

-
- Chinese
 - ▶ English
 - French
 - German
 - Russian
 - Spanish

**Blue Digest
on Automation**

Hesse

99 Examples of Pneumatic Applications

Handling
Pneumatics

Stefan Hesse

99 Examples of Pneumatic Applications

Blue Digest
on Automation

المنارة للاستشارات

Blue Digest on Automation

© 2001 by Festo AG & Co.
Ruiter Strasse 82
D-73734 Esslingen
Federal Republic of Germany
Tel. 0711 347-0
Fax 0711 347-2155

All texts, representations, illustrations and drawings included in this book are the intellectual property of Festo AG & Co., and are protected by copyright law. All rights reserved, including translation rights. No part of this publication may be reproduced or transmitted in any form or by any means, electronic, mechanical, photocopying or otherwise, without the prior written permission of Festo AG & Co.

Some time ago, several hundred companies were asked which of their tasks they considered the most important. The result - the top priority was efficient production. But what exactly does this mean? Efficient production means in practice low machine costs, high and predictable quality and high cost-effectiveness, speed of reaction and equipment availability. This is achieved above all through mechanisation and automation, or in other words through the use of technical devices and processes that partially or completely replace the functions of human beings.

Industrial pneumatics has come to play a major role within this process, and the range of applications of industrial pneumatics is constantly expanding. The reason for this is that pneumatics can offer a virtually seamless range of proven optimised components, available in closely-spaced sizes and specifications to allow the rapid construction of devices on a modular principle. Furthermore, everything that users need, up to and including computer-supported planning aids, are available from a single source.

It is naturally also interesting to consider the uses to which pneumatic components are put and the problem solutions in which they play a leading role. To describe these in full would scarcely be possible, not even in a series of books containing thousands of case studies. The 99 examples in this book, however, demonstrate what pneumatics can do by showing solutions in simplified form in a way that we hope will fire the imagination and encourage new ideas. This book is accordingly aimed at practical technical users, those responsible for rationalisation and also those who are taking their first steps in the world of pneumatics. The book is not a collection of patent recipes, since every problem has its own environment, often a highly specific one, into which the solution must fit. If this collection succeeds as an entry-level guide to rationalisation with compressed air and vacuum, then it will have fulfilled its purpose and will have shown that it is not just hot air (compressed or otherwise)!

Stefan Hesse

1 Selection of automation components	9
2 Examples of pneumatic applications	13
Aligning 01, 02	15, 16
Assembly 03 to 08	17 to 22
Bending 09	23
Buffering 10 to 12	24 to 26
Chamfering 13	27
Clamping 14 to 18	28 to 32
Conveying 19 to 21	33 to 35
Cutting 22	36
Deburring 23	37
Deep drawing 24	38
Destacking 25, 26	39, 40
Drilling 27 to 31	41 to 45
Ejection 32, 33	46, 47
Extraction 34	48
Feeding 35 to 45	49 to 59
Forwarding 46	60
Glueing 47	61
Gripping 48 to 50	62 to 64
Handling 51 to 53	65 to 67
Hopper-feeding 54	68
Indexing 55	69
Insertion 56	70
Lifting 57, 58	71, 72
Linking 59, 59a	73, 74
Loading 60	75
Monitoring 61, 62	76, 77
Orientation 63 to 65	78 to 80
Packing 66	81
Paletting 67	82
Positioning 68, 69	83, 84
Press-fitting 70, 71	85, 86
Pressing 72 to 74	87 to 89
Printing 75	90
Profiling 76	91
Propelling 77	92
Re-orienting 78	93
Re-positioning 79 to 81	94 to 96
Sawing 82, 83	97, 98
Securing 84, 85	99, 100
Separating 86, 87	101, 102
Sorting 88, 89	103, 104
Stopping 90, 91	105, 106

Tensioning	92	107
Testing	93	108
Transferring	94, 95	109, 110
Transporting	96	111
Turning	97	112
Unloading	98, 99	113, 114
Further literature		115
Glossary of technical items		116

Collections of examples have the advantage that the possible uses of components can be demonstrated in a clear way, together with constructive suggestions. This concept is far from new. As early as 1869, H.T. Brown of New York published a book entitled "Mechanical Movements", a collection of no less than 507 examples of ways to convert motions (Fig. 1). Most of these are kinematically oriented and explained through schematic diagrams. The examples of pneumatics were based on antiquity, which should come as no surprise, since what we understand today by "industrial pneumatics" has developed in Europe only since the 1960s. It was in Europe, too, that the process of the comprehensive standardisation of pneumatic components began. It has been estimated that, without standardisation, the cost of technical processes would be some 40% higher.

Fig. 1:
Collections of examples
are not a modern invention.

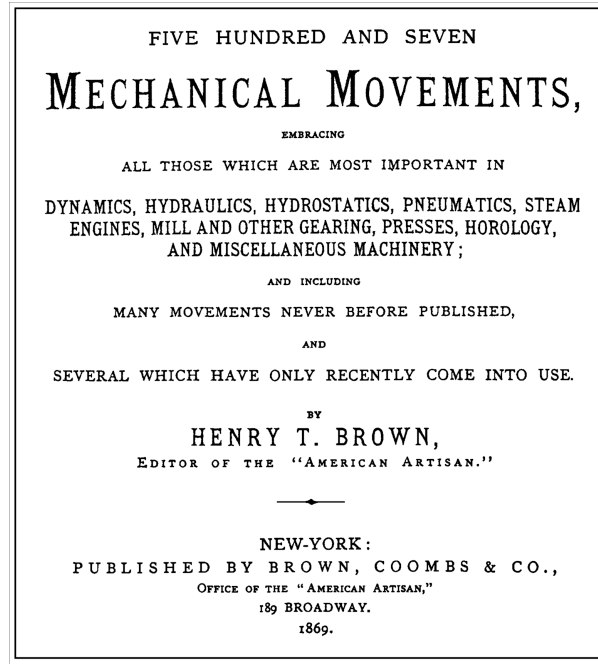

The purpose of examples is above all to stimulate the imagination of engineers and provide suggestions of ways to find high-quality solutions to their own problems. Examples cannot, however, provide patent recipes for solutions. The reason for this is that certain parameters, which can easily be overlooked, can often have a decisive influence on solution concepts. Every solution must therefore be examined critically and tailored to the given real-life situation. In short – suggestions for solutions are not a guarantee of success but merely aids to thinking.

Examples are shown in simplified form to allow the core of the solution to be seen as quickly as possible. The illustrations therefore look unnaturally "tidy" and the reader must imagine the presence of the cable loom and other signal and power lines.

Many illustrations in this collection use the functional symbols of handling technology. This is intended to help the reader think in functions and to explain the solutions shown. For every function (symbol), there are a number of function providers. It is not always easy to find the right function provider (automation component). What is the best way to proceed?

Step 1

Consider which functions are required in sequence and in interdependency. What are the requirements, and what secondary conditions will influence the solution? A symbolic handling plan can be of assistance here.

Step 2

Numerous actions need to be carried out, such as sliding, turning, holding, pressing, clamping and positioning. What drive components should one use for these? The most important factors are size, design, forces and speeds.

Step 3

How will the selected drives be controlled? It is possible to use directional-control, flow-control, shut-off and pressure regulator valves, which can be triggered or actuated by manual, mechanical, electrical or pneumatic means. Factors to consider are flow rates and the fitting of control components, for example using in-line or panel mounting.

Step 4

How will I create the necessary connections between the cylinders and valves? This will involve fittings, tubing, piping, silencers and energy chains and require the specification of nominal sizes and threads.

Step 5

How can I arrive at the “right” kind of air? This involves consideration of the components used in air generation and preparation, from service units, filters, dryers, lubricators and pressure regulators through to shut-off valves and other components used to route compressed air.

Step 6

How can I arrange motion sequences into an overall control concept? This will require electronic evaluation and control devices, sensors and bus systems, and often also facilities for linking pneumatic and electrical/electronic signals and connecting these to higher-level control systems.

It is also necessary to consider with a cool head the degree to which an operation is to be automated. The great theoretician of automation, John Diebold, stated the following in his 1951 book "The Automatic Factory":

"Making a work operation eighty or ninety percent automatic may bring great savings. If, however, attempts are made to automate the remaining ten or twenty percent, this may once again make the entire automation system non-cost effective."

This holds fundamentally true even today. It is a question of the right degree of automation. Too much automation can soon prove costly!

The degree of automation is the quotient of the sum of the weighted automated functions and the sum of the weighted overall functions. Weighting factors make allowance for the period for which functions are used and their importance within the process. The degree of automation can be used, for example, as an index for the comparison of different project concepts.

The following applies as a general rule:

- The more mature the product (module, workpiece),
- the more reliable the long-term service-life expectation and
- the larger the volume of desired production,
- the higher the degree of automation can be.

The following of course also applies:

- The more variable the product structure,
- the more unpredictable the customer's behaviour and
- the more complex the range of products and delivery cycles,
- the greater the required degree of flexibility.

Flexibility is the ability of production systems to be adaptable in all sub-systems to changes in production requirements either through self-adaptation or at least through external adaptation (manual intervention).

Flexible production therefore means the

- cost-effective production of
- different workpieces,
- in any desired sequence and
- in varying quantities.

High degrees of automation and flexibility are opposite extremes. Our aim must therefore be automation with an affordable degree of flexibility. This is easy to say and often enough difficult to do. What is the reason for these difficulties? We live in an age in which production systems are undergoing a fundamental change. Products are becoming more complex, numbers of variants are rising, customers demand instant delivery and product life cycles are becoming shorter and shorter. This process can be seen as a trend in Fig. 2. There is also the demand for lower production costs, which in turn requires a reduction of products' manual labour input.

Fig. 2:
These are the trends
that have a major influence
on production technology.

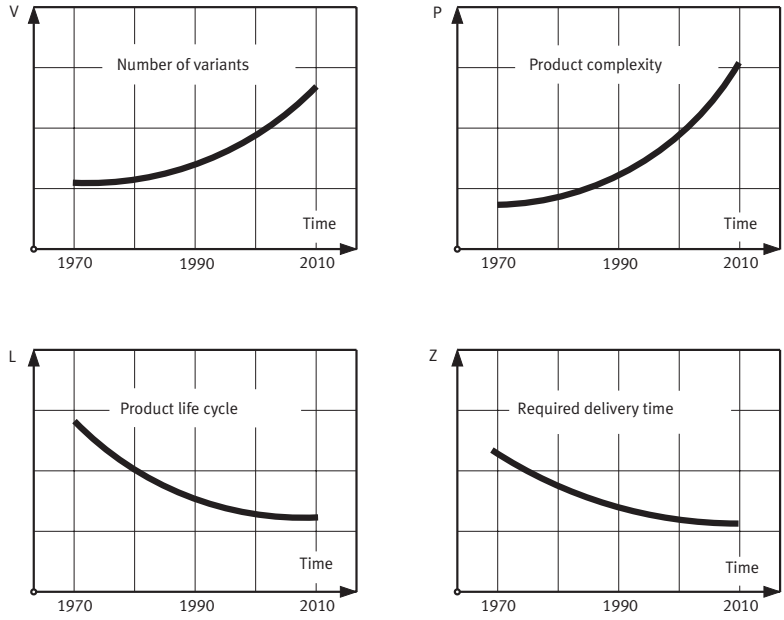

If we were to do justice to the requirements of only one part of this process, then this would jeopardise the entire project solution. As we already know from studies of naturally created systems, it is not as a result of the optimisation of any one individual function that a large scale system can survive, but by virtue of the fact that it is sufficient for as many functions as possible to fulfil these only just well enough. The lesson from this is that we must not think in functions but in processes and must take a holistic approach to the development of solution concepts.

Examples are provided by problem solutions that have been taken out of their complex context and simplified. If they are to be used for other purposes, they must be adapted in terms of details and selected components in such a way that they will operate correctly in a specific environment. Festo offers a wealth of automation components for this purpose. The main groups of available components are as follows:

Cylinders	with operating ranges from 0.1 to 12 bar strokes from 1 to 17,000 mm piston-rod diameters from 1 to 63 mm piston rod diameters from 2.5 to 320 mm thrust values at 6 bar from 2.7 to 43,400 N speeds from 5 to 15,000 mm/s 2 to 4 approachable positions
Rotary drives	with cylinder diameters from 6 to 100 mm angles of rotation from 1 to 360° torque values at 6 bar from 0.15 to 150 Nm operating pressures from 0.5 to 12 bar forces from 15 to 1,500 N
Valves	with connections from M3 to G1 1/2 nominal flow rates from 4 to 30,000 l/min. functions from 2- to 8-way operating pressures from 0 to 12 bar nominal sizes from 0.4 to 40 mm.

If we compare pneumatic drives with other types of drives, we can see that pneumatics is able to cover a very large area of applications. If high actuating forces are required, hydraulics offers advantages, while electrical drives are a better choice for very slow motions. This can be seen in Fig. 3.

Fig. 3:
Areas of applications
of pneumatic drives

- H Hydraulics
(100 to 10,000 N,
100 to 10,000 mm/s)
- M Spindle-motor combination
(0.5 to 2,000 N)
- P Pneumatics
(0.1 to 5,000 N,
10 to 15,000 mm/s)
- S Stepper motor

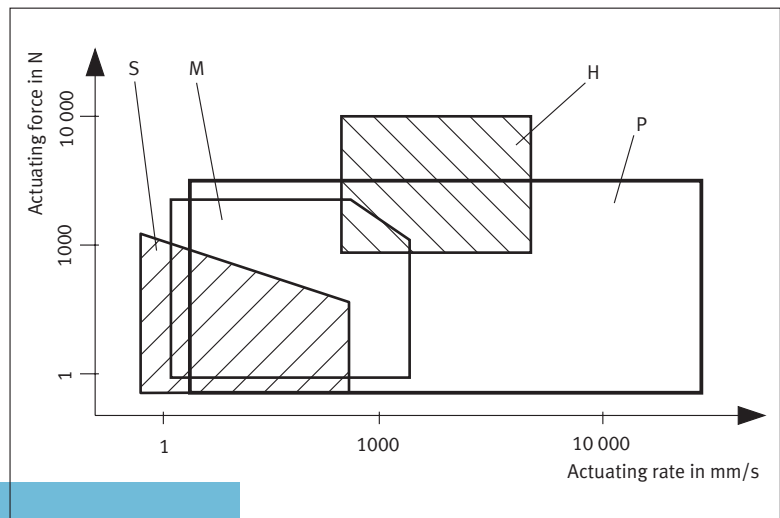

In many examples, function sequences of handling operations have been shown as symbols. Their meaning is shown in Fig. 4. We distinguish between basic symbols (handling, checking and production) symbols for elementary functions (separating, combining, turning, sliding, holding, releasing, testing) and supplementary functions such as random storage (hoppers) and conveying. The defined symbols and function make it easier to describe sequences and also provide a means for the non-solution-specific representation of functions in problem descriptions.

Fig. 4:
Handling symbols
in accordance with VDI 2860

- 1 Handling (basic symbol)
- 2 Orderly storage (magazining)
- 3 Random storage (hoppers)
- 4 Semi-orderly storage (stacking)
- 5 Branching
- 6 Combining
- 7 Clamping
- 8 Unclamping
- 9 Holding (without force action)
- 10 Turning
- 11 Swivelling
- 12 Distribution (of n workpieces)
- 13 Positioning
- 14 Sliding
- 15 Sorting
- 16 Forwarding
- 17 Guiding (whilst maintaining workpiece orientation at all times)
- 18 Testing
- 19 Production process (basic symbol)
- 20 Shape changing (shaping, cutting)
- 21 Treatment (coating, modification of material properties)
- 22 Joining (assembly)
- 23 Shape changing (creative forming)
- 24 Checking (basic symbol)

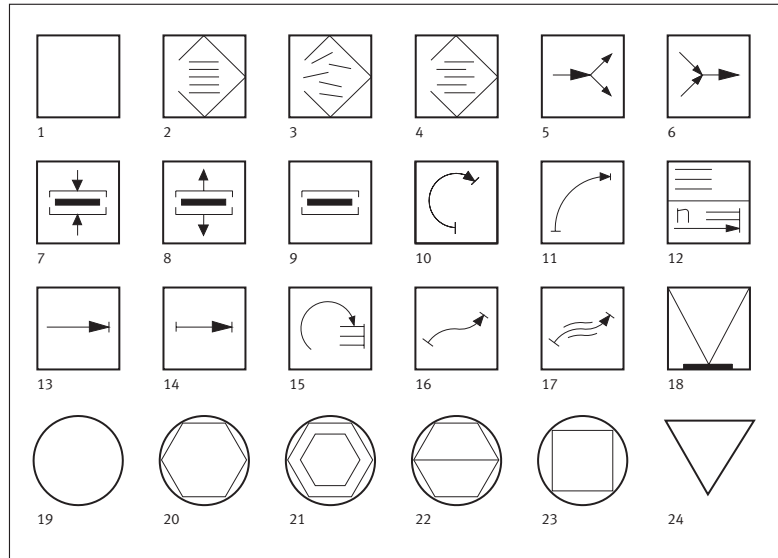

01 Aligning

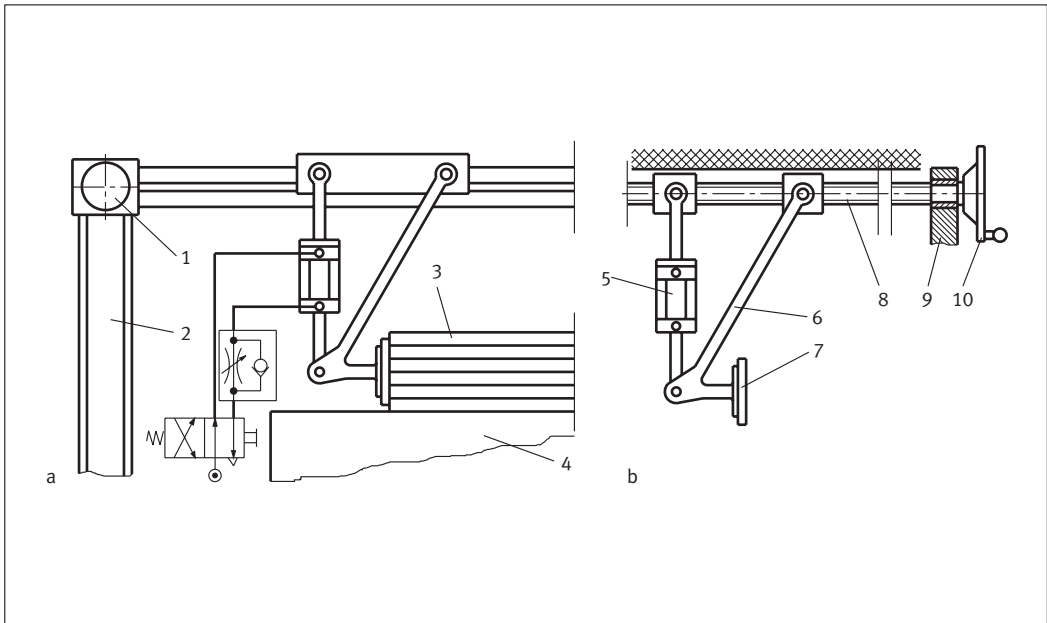

Aligning stacked panels

- a) Automatic stop adjustment
- b) Hand crank adjustment

- 1 Electromechanical linear unit with spindle drive
- 2 Stand
- 3 Stack of panels
- 4 Work table
- 5 Pneumatic cylinder
- 6 Angle lever
- 7 Pressure plate
- 8 Threaded spindle
- 9 Frame
- 10 Hand wheel

The illustration shows a kinematic solution for the dimension-specific alignment of panel working materials, particularly chipboard panels. In the case of the automatic chipboard panel cutting machines used in the furniture industry, the panels must be precisely aligned to the cutting line into order to achieve precise sawing. Since chipboard panel sections are required in varying batch sizes and different dimensions, suitable adjustment gear must be provided. This allows programmable adjustment of the stop system (CNC control system) to the required dimensions. The alignment stop (positioning gear) is actuated by a pneumatic cylinder. To be strictly accurate, the device consists of two independently operating gear units and a pneumatically powered crank drive.

Suitable components:

Standard cylinder DNG...
 Swivel flange SNG...
 Rod eye SGS...
 Pneumatic single pilot valve VL...
 Proximity switch SME...
 Electromechanical linear drive DGE...
 Axis controller SPC...
 One-way flow control valve GR...

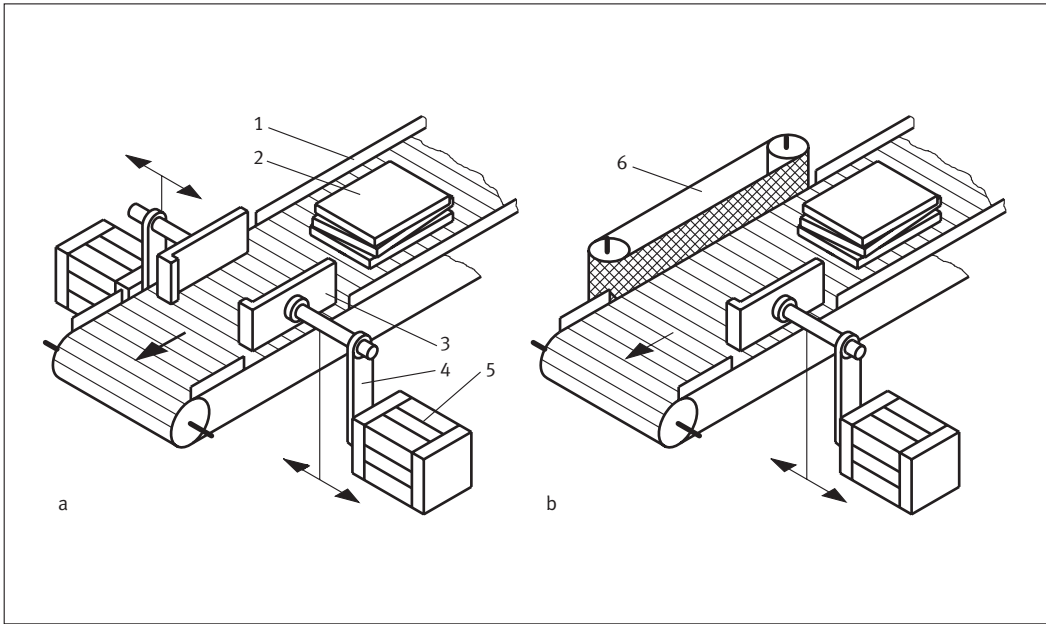

Alignment mechanism for stacked panels

- a) Double slide principle
b) Side slide principle

- 1 Side guide
2 Stack of panels
3 Alignment plate
4 Arm
5 Pneumatic cylinder
6 Driven side conveyor belt

Before panel workpieces can be packed, transported or bundled, they must be arranged in a reasonably tidy stack, i.e. with flush edges. This can often be carried out on a continuous throughput basis, using for example stop rollers positioned above a conveyor belt. In the present example, however, pneumatically driven slides are used. As the workpieces are also halted briefly in the direction of conveyance, control of the slide opening can be used to obtain even spacing of workpieces on the conveyor belt. In the case of the solution with a “rolling” side edge, it is even possible under favourable conditions and with smooth workpieces to achieve alignment of the stack on two axes (longitudinal and transverse). In this case, the side conveyor belt must have a textured profile and must be driven. The alignment operation is triggered by a sensor detecting the workpiece (not shown).

Suitable components:

Flat cylinder DZF... or
Short stroke cylinder ADVUL... or
Short stroke cylinder ADVULQ... or
Twin cylinder DPZ..., installed directly at conveyor belt height (without arm)
Pneumatic single pilot valve VL...
Proximity switch SME...
Diffuse sensor SOEG...
Pneumatic adding counter PZA...

03
Assembly

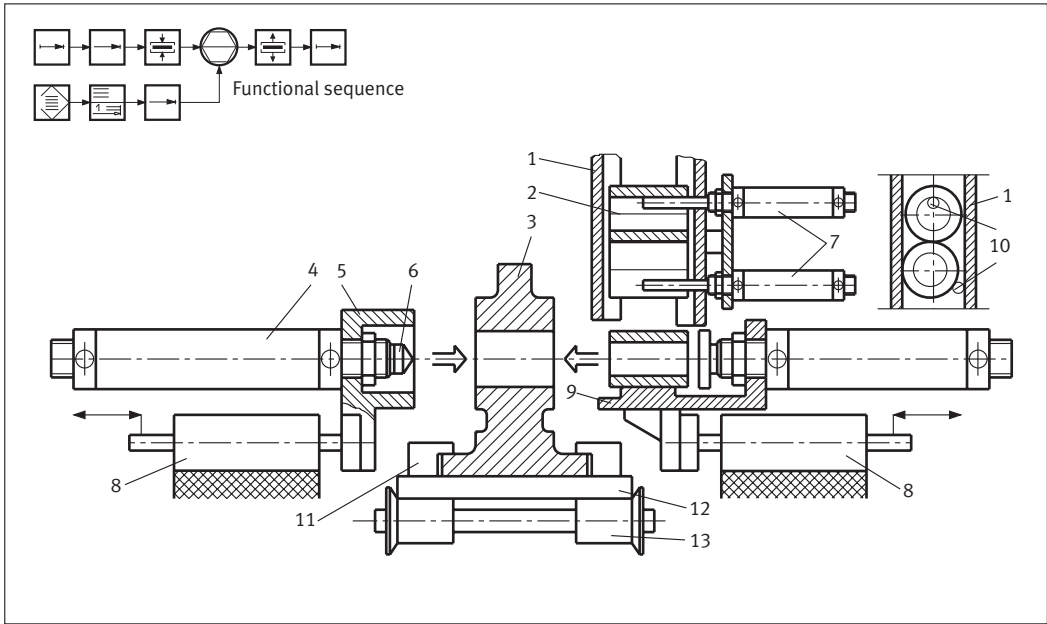

Assembly station for bearing bushes

- 1 Magazine
- 2 Joining part (bearing bush)
- 3 Basic assembly component
- 4 Centring mandrel cylinder
- 5 Counterholding and clamping sleeve
- 6 Tapered centring attachment
- 7 Distributor drive cylinder
- 8 Linear unit
- 9 V-support for joining part
- 10 Distributor pin
- 11 Clamp claw for basic component
- 12 Workpiece carrier
- 13 Transfer system roller conveyor

In the assembly of bushes using a longitudinal pressing action, it is very important that the two components to be assembled are in precise coaxial alignment to each other. To achieve this in the example shown, a counterholding clamp sleeve is first applied to the basic component, and a centring mandrel is then run through this component to the bush located on the other side. This operation produces axial alignment to within very close tolerances. The bush is thus introduced into the bore during the press-fitting operation. All motions are produced by pneumatic actuators. These motions include the separation of the bushes from the stack magazine and the clamping of the basic component by the two linear units. These operations are followed by the actual assembly of the two workpieces, during which the centring mandrel is pushed back, finally returning to its initial position. The clamping of the basic component ensures that no impermissible forces act on the transfer system or workpiece carrier. At the end of the operation, the two linear units return to their initial position, allowing the workpiece carrier to be moved on without obstruction.

Suitable components:

- Standard cylinder ESN...
- Round cylinder DSW...
- Guide unit DFM...
- Pneumatic single pilot valve...
- Proximity switch SM...
- Fittings, Mounting accessories

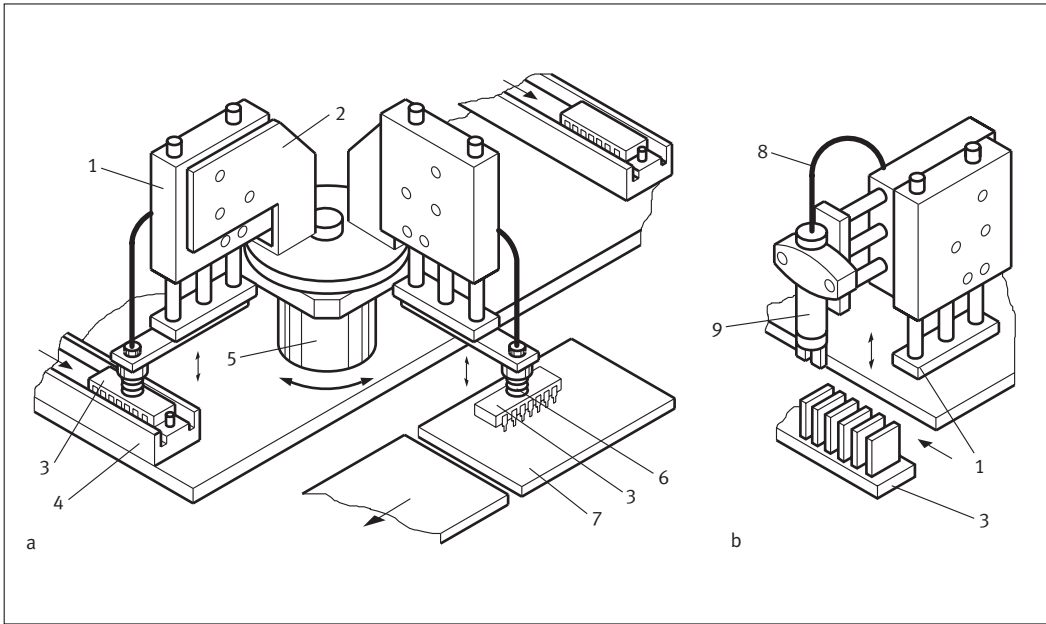

Miniature handling device

- a) Twin-arm mini handling device
- b) Mini pick-and-place unit

- 1 Mini guide unit
- 2 Support arm
- 3 Workpiece (electronic chip)
- 4 Feed magazine
- 5 Rotary unit
- 6 Bellows suction cup
- 7 Basic assembly component
- 8 Compressed air tubing
- 9 Micro gripper

The reduction in the size of products and modules in the fields of precision engineering, optics and electronics requires similarly miniaturised versions of handling devices, assembly units, feed systems and grippers. Suction cup grippers are the most common type of gripper found on miniature assembly machines such as SMD automatic component-fitting machines. Miniature versions of clamp-type grippers are, however, also used, as shown in the example above. This features an angle gripper with stroke compensation. New designs of grippers for miniature components are constantly being announced, including designs which exploit adhesion effects or cryogenic functions (freezing of workpieces). In order to speed up the cycle time, the gripping and assembly functions in the configuration shown in Fig. a are carried out in parallel. To achieve this, mini guide units have been mounted on a rotary unit, thus creating a twin-arm assembly device.

Suitable components:

- Swivel module DSM... or rotary drive DRQD...
- Pneumatic single pilot valve...
- Bellows suction cup VASB...
- Proximity switch SM...
- Mini guide unit DFC...
- Micro gripper HGWM...
- Mounting accessories and fittings

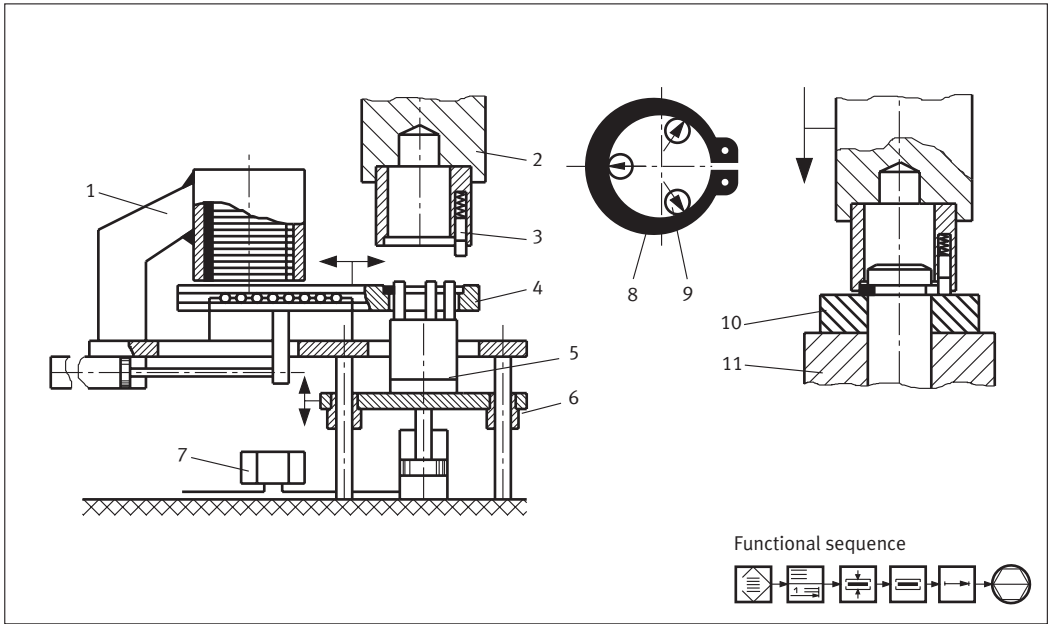

Assembly device to fit circlips to shafts

- 1 Circlip magazine
- 2 Fitting head
- 3 Tapered piece
- 4 Feed slide
- 5 Three-point gripper
- 6 Lifting plate
- 7 Spreading-force regulator
- 8 Circlip
- 9 Gripper finger
- 10 Joining part
- 11 Basic assembly component

Shaft circlips are often used to secure components in mechanical-engineering devices. Various mechanisms have been developed to allow the fitting of these circlips. In the above example, circlips are separated out of a magazine by a slide and brought to a spreading station. Once each circlip has been spread, it is fixed into place in the robotised holding device by a tapered piece. When this comes into contact with the assembly module, the tapered piece retracts and the circlip now snaps into place in the slot at the end of the shaft. It is important that the circlip should not be stretched excessively during this operation, which could lead to plastic deformation. The opening of the gripper fingers is thus duly controlled by a spreading-force regulator. The radial gripper at the same time precisely defines the axis centre to which the handling device is aligned. The fitting head can also be mounted on a pneumatic handling device.

Suitable components:

- Three-point gripper HGD...
- Compact cylinder ADVUL...
- Pressure regulator LR...
- Pneumatic single pilot valve...
- Standard cylinder ESN... or slide SLG...
- Proximity switch SM...
- Fittings
- Mounting accessories

06
Assembly

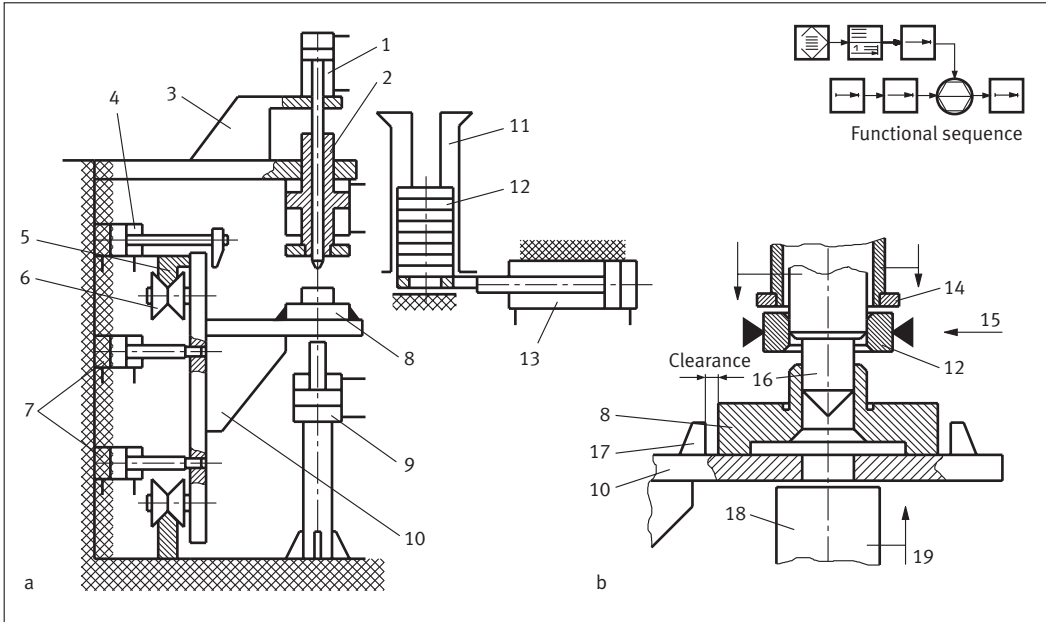

Assembly station
for light press-fitting work

- a) Section through assembly station
- b) Function of centring mandrel

- 1 Centring cylinder for axial assembly direction
- 2 Press cylinder
- 3 Stand
- 4 Clamp cylinder
- 5 Guide profile
- 6 Support roller
- 7 Indexing cylinder
- 8 Basic assembly component
- 9 Support cylinder
- 10 Carriage platform
- 11 Magazine
- 12 Additional assembly component
- 13 Distributor cylinder
- 14 Press ring
- 15 Distributor motion
- 16 Centring mandrel
- 17 Basic assembly component carrier
- 18 Piston rod of support cylinder
- 19 Advance motion of support cylinder

The transfer system of this assembly installation consists of assembly platforms which circulate on rails. Within the station, the platforms are indexed and clamped by pneumatic means. The additional assembly component is fed in and held ready in the assembly position. Before the press-fitting operation, the assembly axes are positively aligned by means of a centring mandrel. Moreover, a support cylinder advances to provide compensation for the assembly force, thus relieving the load on the assembly platform. The drive for the carriage transfer is not shown. This drive can, for example, take the form of a circulating chain. There are also carriages with their own electric drive motors.

Suitable components:

- Standard cylinder DSNU...
- Short stroke cylinder ADVC...
- Short stroke cylinder AEVC... or toggle-lever clamping system CTLF...
- Compact cylinder ADVU... .S20
- Pneumatic cylinder...
- Proximity switch SM...
- Mounting accessories
- Fittings

07
Assembly

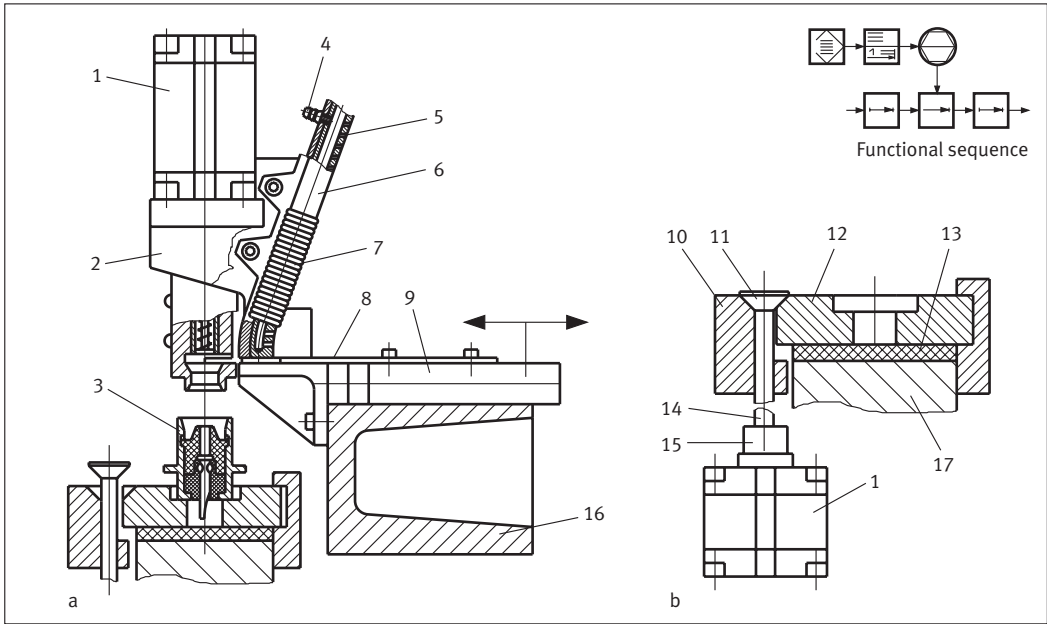

Fitting station for circlips

- a) Sectional view of fitting station
- b) Indexing and clamping of workpiece carrier

- 1 Pneumatic cylinder
- 2 Support
- 3 Assembly module
- 4 Compressed air supply connection
- 5 Air outlets
- 6 Magazine tube for circlips
- 7 Circlip
- 8 Distributor slide
- 9 Slide unit
- 10 Guide
- 11 Centring and clamping taper
- 12 Workpiece carrier
- 13 Conveyor belt
- 14 Tie rod
- 15 Cylinder mounting
- 16 Cast frame
- 17 Conveyor belt system

The circlips are gathered on a tube-like mandrel magazine. To prevent them from sticking together as they move up, air is injected and exits from holes in the tube, ensuring low friction between the circlips and magazine tube. The distributor slide brings each circlip under the press ram. This moves downwards, makes contact with the circlip and then press-fits this. The circlip leaves the guide at the end of the stroke and springs into the annular slot in the workpiece. The workpiece carrier is centred and at the same time clamped by several tapered pins (IF Werner system). The tapered pins need only execute a short stroke in order to clamp or release the workpiece carriers.

Suitable components:

- Compact cylinder ADVUL...
- Proximity switch SM...
- Mini slide SLF...
- Pneumatic single pilot valve....
- Short stroke cylinder ADVU...
- Mounting accessories
- Fittings

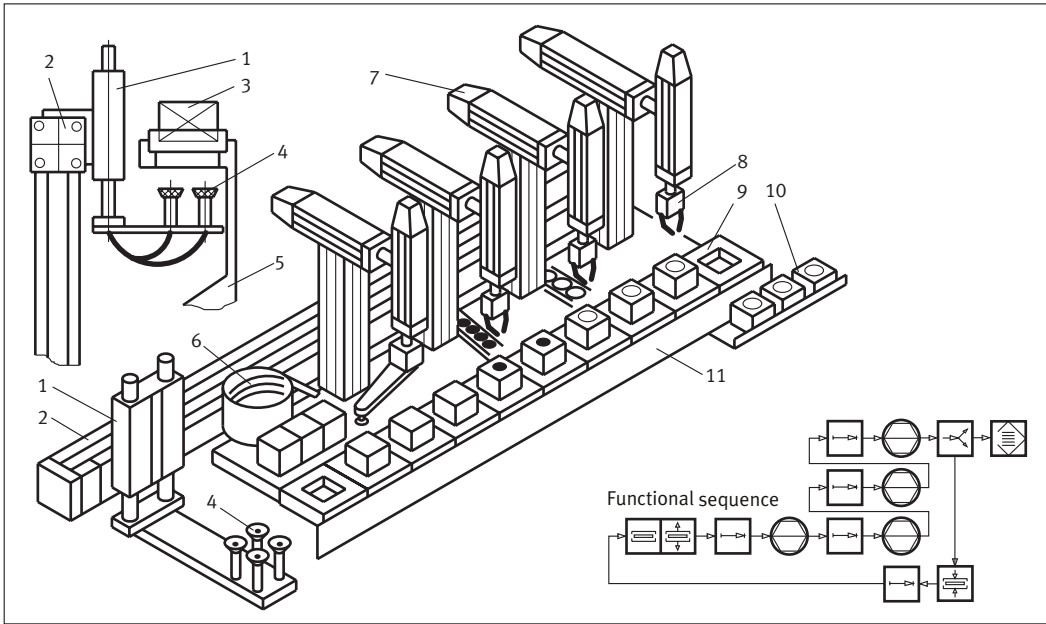

Assembly transfer installation

- 1 Lifting slide
- 2 Rodless linear unit
- 3 Assembly module
- 4 Suction cup
- 5 Machine frame
- 6 Vibrator for small-work-piece feed
- 7 Pick-and-place unit
- 8 Gripper
- 9 Workpiece carrier
- 10 Finished module
- 11 Lateral guide

This example features an assembly installation with driveless transfer of the workpiece carriers. As a finished module is removed at the end of the assembly line, the workpiece carrier is gripped from below by suction cups, lowered and returned below the transfer line. The workpiece carrier is then lifted and placed back at the beginning of the line. As all the workpiece carriers are in immediate juxtaposition without gaps, the effect of this is to index the entire chain of carriers forward by one unit. A remarkable feature is that this principle of small component assembly can be produced largely from standard components.

Suitable components:

- Rodless linear unit DGPL...
- Mounting accessories
- Vacuum suction cup VAS...
- Fittings
- Proximity switch SM...
- Guide unit DFM...
- Linear module HMP..
- Vacuum efficiency valve ISV...
- Vacuum generator VADM...
- Gripper HG...
- Swivel module DSM...

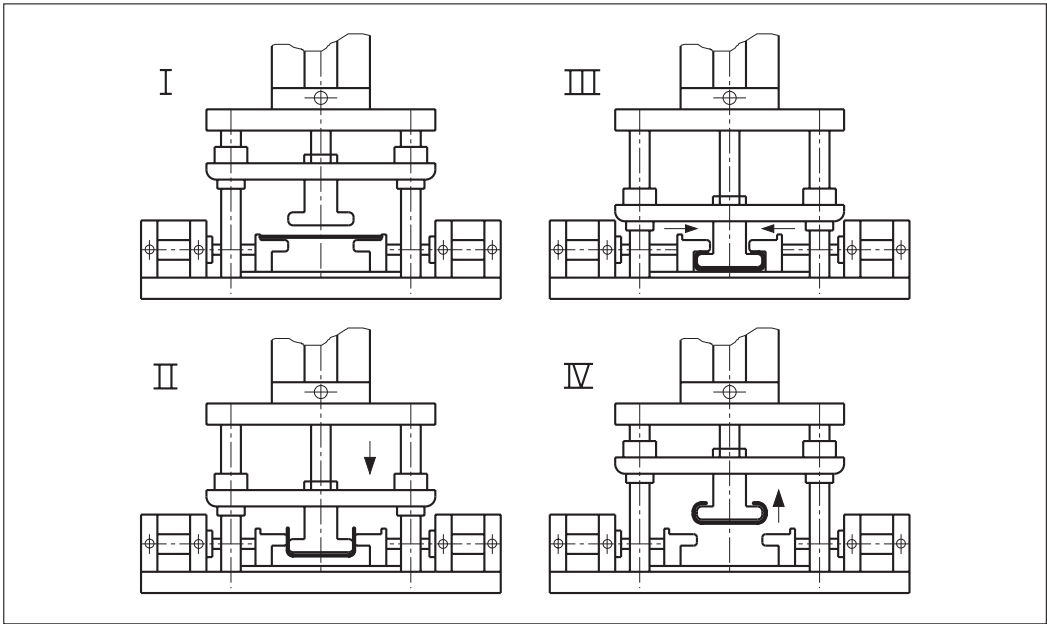

**Bending tool
with pneumatic drive**

**I to IV Bending sequence,
column frame with 2 or 4
guide columns and straight
guides are standard commercially
available components.**

Small bent workpieces can be produced to good advantage without the need for an eccentric or hydraulic press by using standard commercially available components to create a basic configuration and pneumatic components to provide the necessary motions in numerous directions. The illustration shows a bending sequence. The lateral bending jaws can be activated only after the vertical motion has been completed. The sequence control system thus requires signals supplied by proximity switches. The finished workpiece must be pushed away from the bending ram. In the case of full automation, the insertion of a new workpiece blank can be combined with the ejection of a finished workpiece. If a single cylinder is not able to deliver the required force, twin cylinders are used.

Suitable components:

Short stroke cylinder ADVU... or twin cylinder ADVUT...
Self-aligning rod coupler FK...
Standard cylinder DNGUL...
Proximity switch SME...
Pneumatic single pilot valve VL...
Mounting accessories

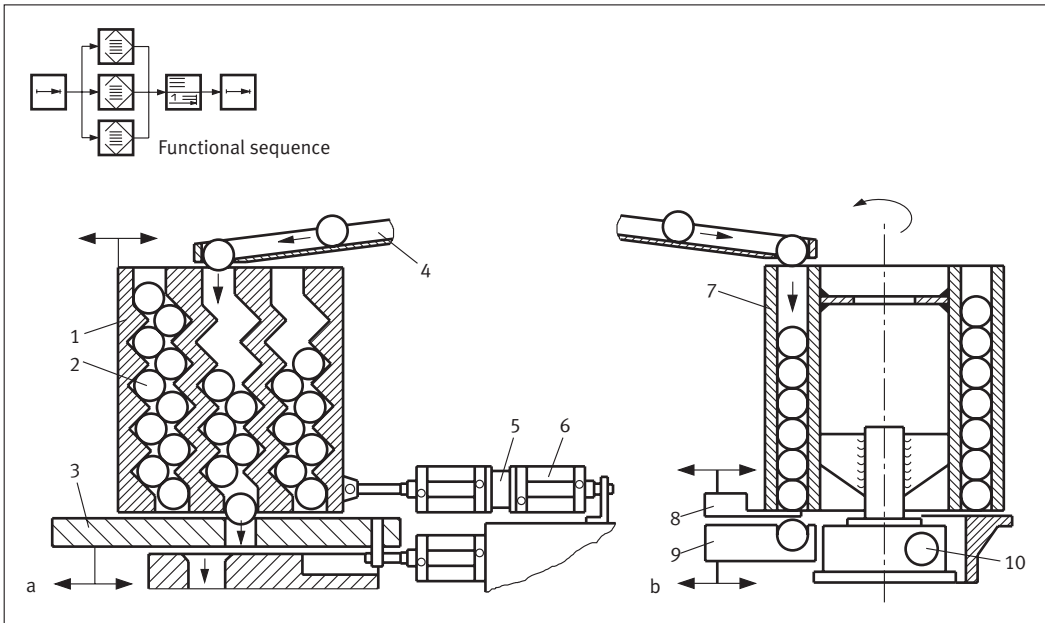

Multi-row intermediate buffer store

- a) Slide magazine
- b) Rotary magazine

- 1 Zig-zag rail
- 2 Workpiece
- 3 Feed slide
- 4 Feed channel
- 5 Mounting kit
- 6 Multi-position cylinder
- 7 Drum magazine
- 8 Blocking device
- 9 Feed device
- 10 Rotary indexing table fitted with magazine

Buffer stores are a useful addition to a material flow system as a means of decoupling workstations or machines. For increased capacity, several magazines can be installed in parallel, as in the example above. Filling levels must be monitored by sensors (not shown). Magazines are activated by pneumatic drives such as multi-position cylinders or pneumatic rotary indexing tables. At each stage of their zig-zag passage through the magazine shown in Fig. a, the workpieces are re-aligned, allowing an empty magazine to be re-filled without workpieces overlapping. In the solution shown in Fig. b, 4 magazines, for example for cylinder components, are arranged on the periphery of the drum.

Suitable components:

Standard cylinder DNC...
 Multi-position kit DPVU...
 Compact cylinder ADVU...
 Proximity switch SM...
 Pneumatic single pilot valve...
 One-way flow control valve GR...
 Rod eye SGS...
 Rotary indexing table
 Mounting accessories
 Fittings

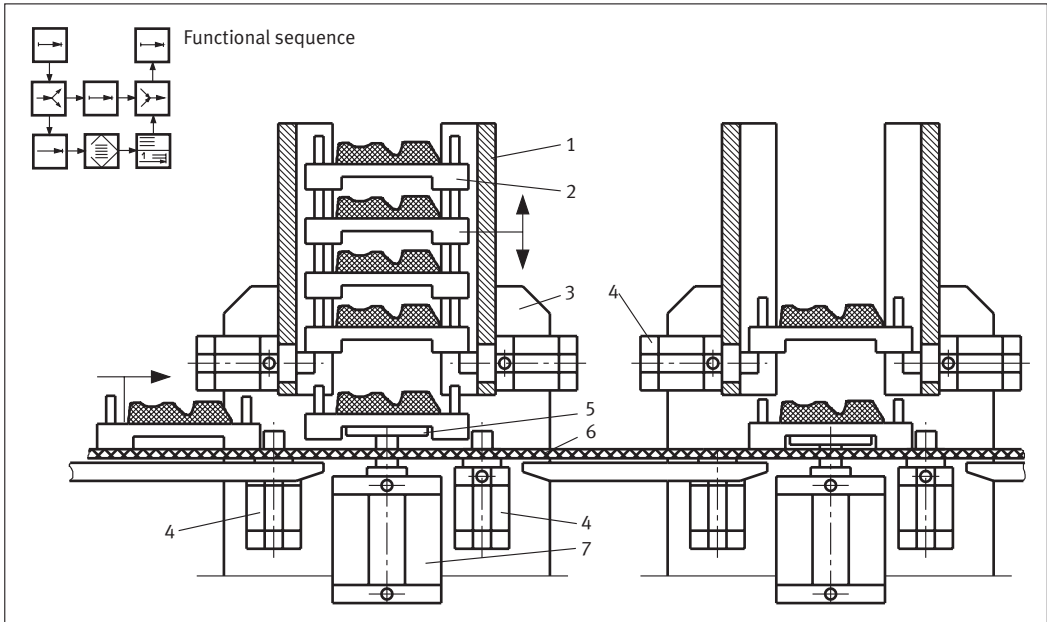

Transfer line section with buffer unit

- 1 Magazine
- 2 Workpiece carrier
- 3 Stand
- 4 Stopper cylinder
- 5 Lifting plate
- 6 Conveyor belt
- 7 Pneumatic cylinder

Modern production line stations are generally linked together loosely, since this allows a higher output to be achieved than in the case of fixed links. The reason for this is that in the case of a malfunction in one station, the other stations are able to keep working, at least for a certain time. In order to achieve this, malfunction buffers must be installed between the stations. Under normal conditions, the workpiece carriers go straight through. If, however, the downstream station is malfunctioning, the workpiece carriers are lifted off the transfer line and buffered. This means that it is necessary to switch off the upstream station only when the buffer is full. The illustration shows a design solution that provides this function. In order to ensure that the buffer filling and emptying operations run smoothly, the upstream workpiece carriers must be halted briefly. Pneumatic cylinders are a very good means of lifting, locking and stopping the workpiece carriers. The design of the buffer stores is uncomplicated.

Suitable components:

Stopper cylinder STA...
 Proximity switch SM...
 Pneumatic single pilot valve...
 Compact cylinder ADVUL...or ADVULQ...
 One-way flow control valve GR...
 Mounting accessories
 Fittings

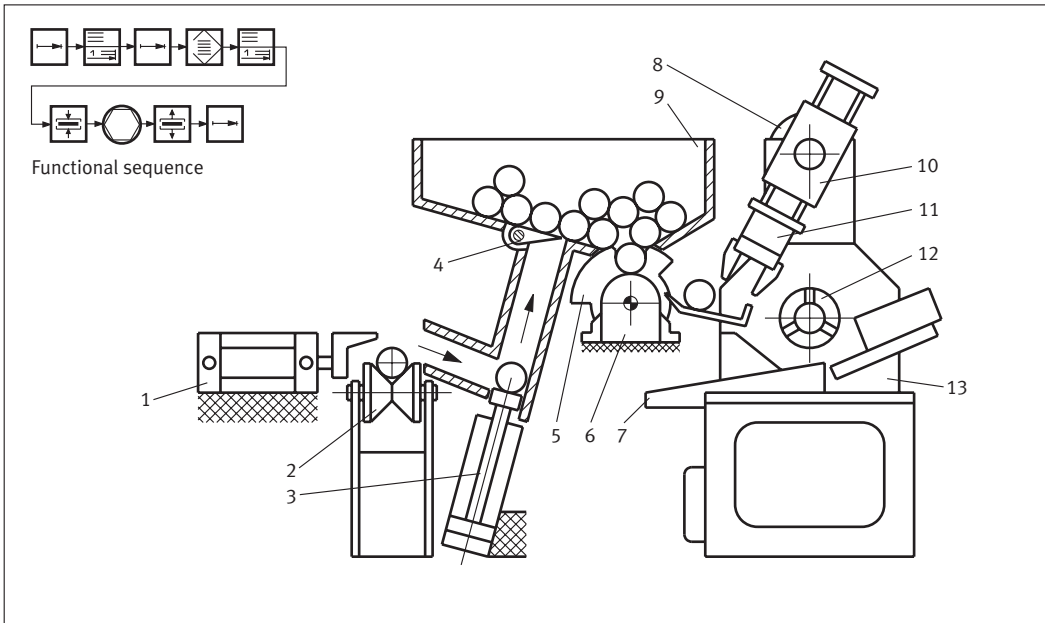

Feeding and buffering of bar workpieces

- 1 Pusher cylinder
- 2 Roller conveyor (linking conveyor)
- 3 Inserter
- 4 Spring-loaded detent
- 5 Feeder
- 6 Rotary drive
- 7 Output chute
- 8 Rotary/linear unit
- 9 Stack magazine
- 10 Linear unit
- 11 Gripper
- 12 Clamping device
- 13 Machine tool

Buffer stores have the task of decoupling pieces of production equipment from each other and thus providing loose linkage which results in better overall system performance in cases of individual machine malfunctions. The illustration shows a buffer store which accepts bar material (for example, with diameters of 10 to 30 mm and lengths of 150 to 600 mm) from a conveyor belt, stores this temporarily and outputs to a machine tool on demand. All the necessary motions can be produced using pneumatic components. The workpieces which are pushed off the roller conveyor pass to the inserter and are stored in the stack magazine. On removal from this, the workpieces are separated by a rotary feed device and fed to the machine tool by a three-axis handling unit. The system achieves a cycle time of around 5 seconds.

Suitable components:

Compact cylinder AEVU...
 Standard cylinder DNC...
 Foot mounting HNC...
 Semi-rotary drive DSR...
 Linear unit DPZ]...
 Parallel gripper HGP...
 Proximity switch SM...
 Pneumatic single pilot valve...
 Mounting accessories and fittings

13 Chamfering

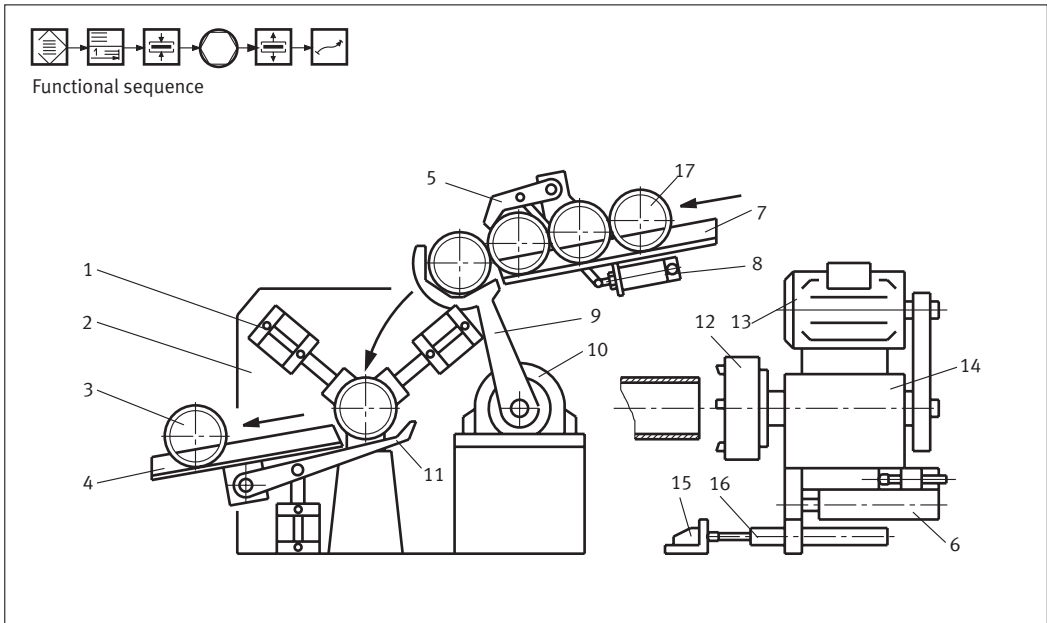

Special machine for chamfering pipe ends

- 1 Clamping cylinder
- 2 Machine frame
- 3 Machined workpiece
- 4 Output roller conveyor
- 5 Distributor
- 6 Linear unit
- 7 Roller conveyor magazine
- 8 Pneumatic cylinder
- 9 Insertion arm
- 10 Rotary drive
- 11 Ejector
- 12 Cutter head
- 13 Electrical motor
- 14 Spindle unit
- 15 Stop
- 16 Hydraulic cushioning cylinder

Pipe sections are frequently required in random lengths and with chamfered ends. The working units at each end of this special machine can be adjusted for different workpiece lengths. The handling system used to insert and remove the workpieces can be of a relatively simple design using pneumatic actuators. In the example shown, the workpieces are taken from a roller conveyor magazine and output to another roller conveyor magazine after machining. The workpieces are clamped during machining; i.e. the tool executes the necessary motion. The feed motion of the slides can be made smoother if a hydraulic cushioning cylinder is connected in parallel with the working motion.

Suitable components:

Linear unit SLT... or DFM... or DGPL...-HD...
 Pneumatic single pilot valves VL...
 Semi-rotary drive DSR...
 Proximity switch SME...
 Hydraulic cushioning cylinder YDR...
 Mounting flange YSRF...
 Short stroke cylinder ADVU...
 Round cylinder DSEU...
 Mounting accessories

14
Clamping

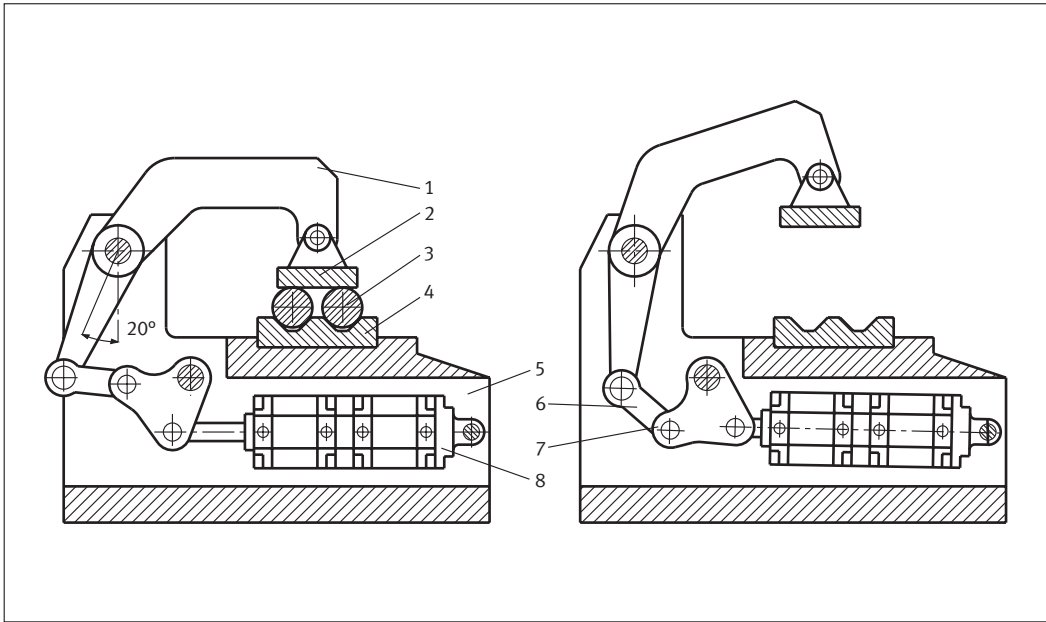

Double clamping device

- 1 Clamp arm
- 2 Pressure piece
- 3 Workpiece
- 4 V-clamp
- 5 Device body
- 6 Toggle lever
- 7 Link lever
- 8 Twin cylinder

Clamping is a fundamental function in production processes. Correct clamping plays a large part in ensuring high workpiece quality. A floating pressure piece ensures that the force holding the workpieces in the v-clamp remains constant. It can be seen that the force flow path includes a toggle lever which generates a high force F towards the end of the clamping stroke when it is fully stretched. This force is distributed between two workpieces, with the result that each is clamped with a force $F/2$. With the clamping device open, there must be sufficient space for the infeed of workpieces. Provision must also be made for a free flow of machining chips. Notwithstanding this, the clamping points must be cleaned after 15 to 20 workpieces have been machined. It must be possible to carry this out without injury. It would also be possible to use CTLF toggle-lever clamping systems for this application. These are well-protected and proven modules and can greatly simplify system design work. The opening angle of the clamp arm can be adjusted to between 15 and 135°.

Suitable components:

- Twin cylinder ADVUT...
- Proximity switch SM...
- Pneumatic single pilot valve....
- Rod clevis SG...
- Clevis foot mounting LBG...
- Mounting accessories
- Fittings

15 Clamping

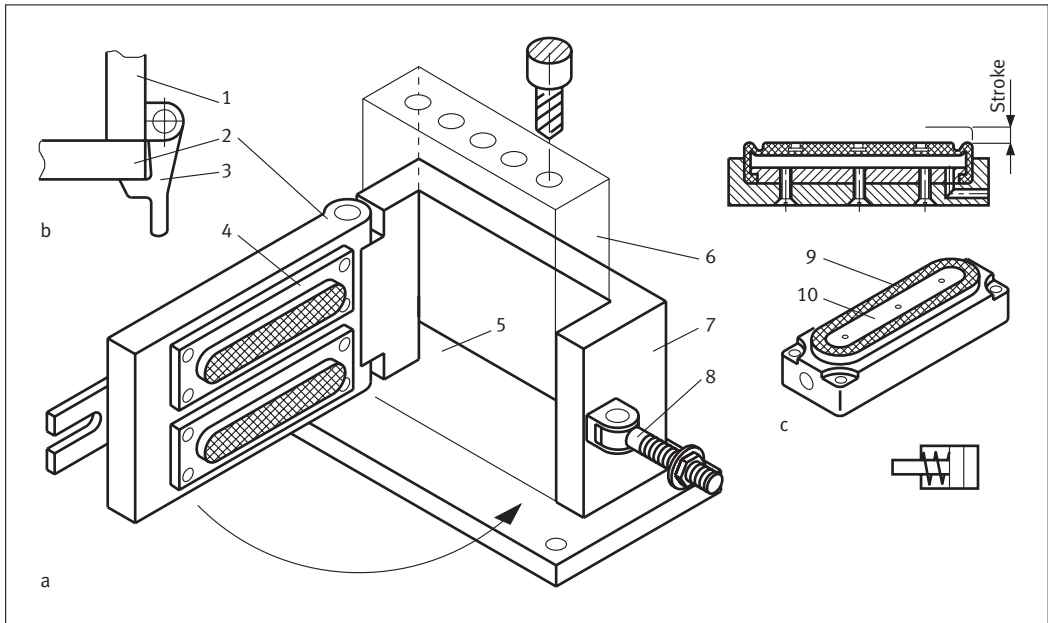

Clamping device for v-shaped workpieces

- a) View of clamping device
- b) Design variant with clamp flap closure
- c) Diaphragm clamping module

- 1 Side wall
- 2 Clamp flap
- 3 Closure
- 4 Clamping module
- 5 Aperture to facilitate cleaning
- 6 Workpiece
- 7 Clamping box
- 8 Closure bolt
- 9 Diaphragm clamp
- 10 Pressure plate

Clamping devices should not only clamp well but also be easily accessible for supply and feeding purposes. The example shows a clamp for v-shaped workpieces which are to be drilled. The clamping force is generated by pneumatic pressure components. These are integrated into the clamp flap. The flap opens very wide, thus allowing the removal of workpieces from the front without the risk of collision. A simple detented closure device as shown in Fig.b, is sufficient. The rear support surface of the device features an open slot that allows efficient removal of machining chips. The diaphragm components carry clip-on metal pressure plates to protect the rubber diaphragms from abrasive wear. The use of clamping modules makes it possible to achieve a very simple clamp design. These are available in round and rectangular forms and in different sizes.

Suitable components:

Clamping module EV...
 Pressure plate EV... DP
 Pneumatic single pilot valve...
 Mounting accessories
 Fittings

16
Clamping

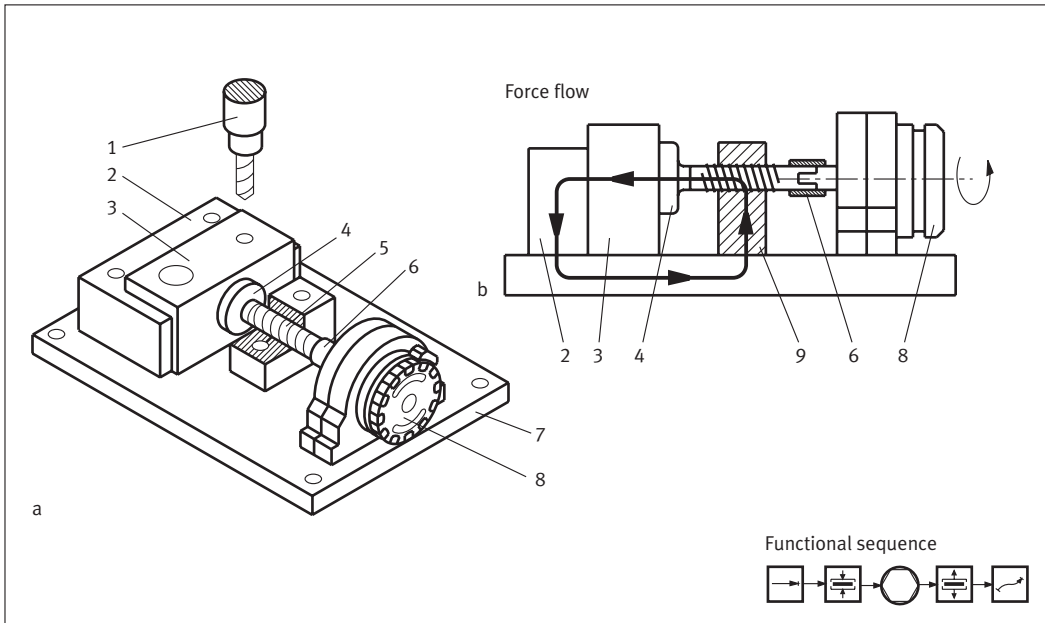

Pneumatic spindle clamp

- a) Overall view of device
- b) Force flow

- 1 Drill spindle
- 2 Workpiece carrier
- 3 Workpiece
- 4 Pressure plate
- 5 Spindle
- 6 Coupling
- 7 Base plate
- 8 Semi-rotary drive
- 9 Fixed spindle nut

Almost all workpieces which are to be machined must first be clamped securely. Suitable clamping devices can be produced with all kinds of components. In the example shown above, a pneumatic semi-rotary drive is used to generate the clamping force. The clamping travel which can be achieved is determined by the pitch of the spindle and the angle of rotation of the rotary drive. The clamping force F is calculated from the torque M and spindle pitch h as $F = M/h$ minus the frictional forces in the spindle drive. As the swivel unit is able to absorb only low axial forces, the force flow is routed via the spindle nut into the base plate of the device. This keeps reactive axial forces away from the output shaft of the swivel unit. The spindle must be self-locking. The disadvantage of this solution is the small clamping travel, due to the fact that the semi-rotary drive is able to execute only a half turn. The advantage is the simple design.

Suitable components:

- Swivel unit DSR...
- Foot mounting HSR...
- Proximity sensors SM...
- Pneumatic single pilot valve...
- Mounting accessories
- Fittings

17 Clamping

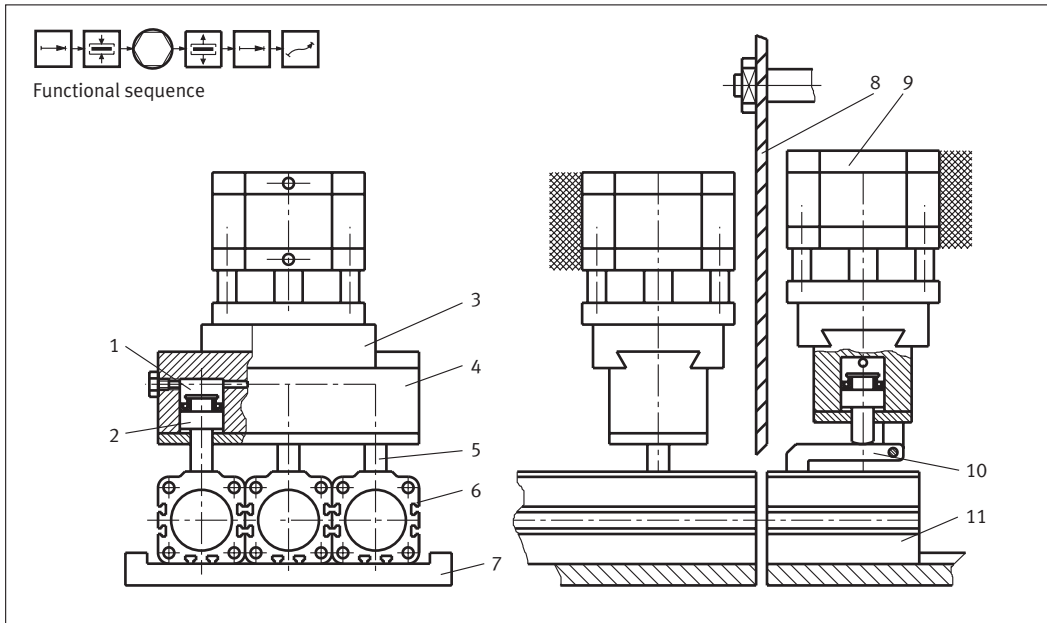

Multiple clamping system

- 1 Oil chamber
- 2 Pressure piston
- 3 Clamp body
- 4 Adapter
- 5 Pressure piston rod
- 6 Workpiece (profile bar)
- 7 Clamping support
- 8 Circular saw blade
- 9 Pneumatic cylinder
- 10 Clamp lever
- 11 Sawn-off part

Multiple clamping systems can be used to good advantage in cutting-to-length processes. The example above shows aluminium profiles being cut to length, 3 at a time. Parallel clamping, however, requires pressure components which are able to compensate for slight dimensional differences. For example, sets of cup springs can be installed for this purpose. The illustration shows a fluid power solution. To be precise, this solution involves a “fluid spring”, or in other words a passive hydraulic system. It is important, by the way, to ensure when filling the oil chamber that one piston is in its retracted end position, since otherwise insufficient stroke volume would be available and the small pistons would not be able to move and transmit power. If the adapter is made interchangeable, a stock of adapters can be kept to hand for various different profile dimensions. This increases the flexibility of the clamping device.

Suitable components:

Compact cylinder ADVUL...
 Pneumatic single pilot valve...
 Proximity switch SM...
 Mounting accessories
 Fittings

18
Clamping

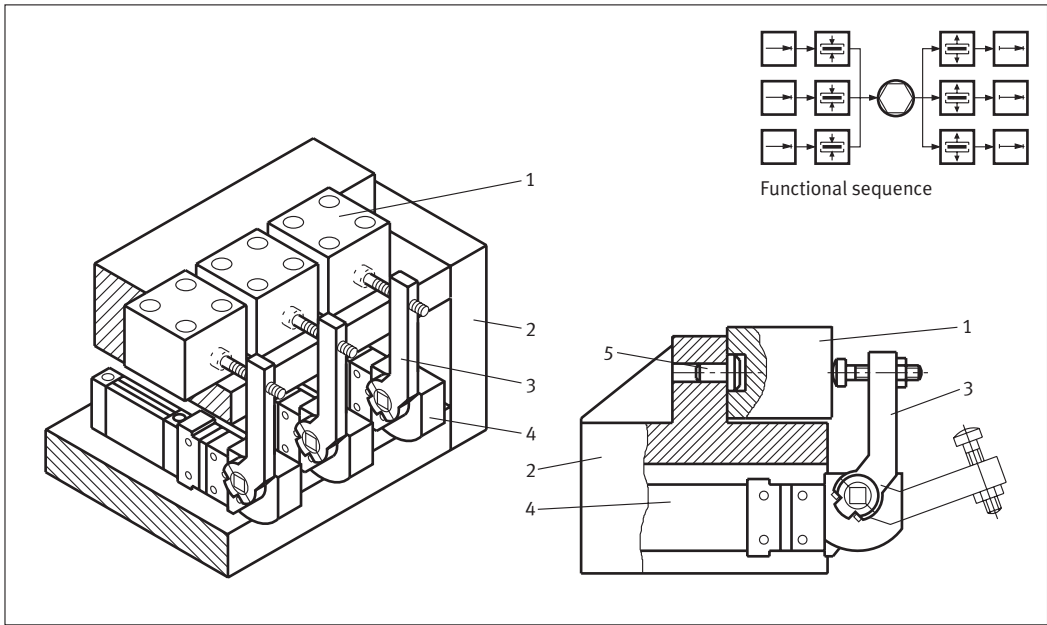

**Multiple clamping device
for v-shaped workpieces**

- 1 Workpiece
- 2 Device body
- 3 Clamp arm
- 4 Toggle-lever clamp
- 5 Centring piece

Multiple clamping devices have the advantage that they help save auxiliary process time. The times for clamping, releasing and the advance and retraction of a tool are shared among a number of workpieces, which helps boost productivity. Multiple clamping devices are thus often used in high-volume production operations. In the above example, toggle-lever clamping systems are used in a parallel configuration to generate clamping force. This configuration is made possible by the slim design of these units and reduces the mechanical complexity of the clamping device. The workpieces can be accessed easily by the tool from above, which is often not the case with other types of device. The opening angle of the systems are also well protected against machining chips. Thanks to the fact that the clamp arms swing well away from the workpieces, this device is also suitable for automatic feed with a pick-and-place handling device.

Suitable components:

- Toggle-lever clamping system CTLE...
- Proximity switch SM...
- Pneumatic single pilot valve...
- Mounting accessories
- Fittings

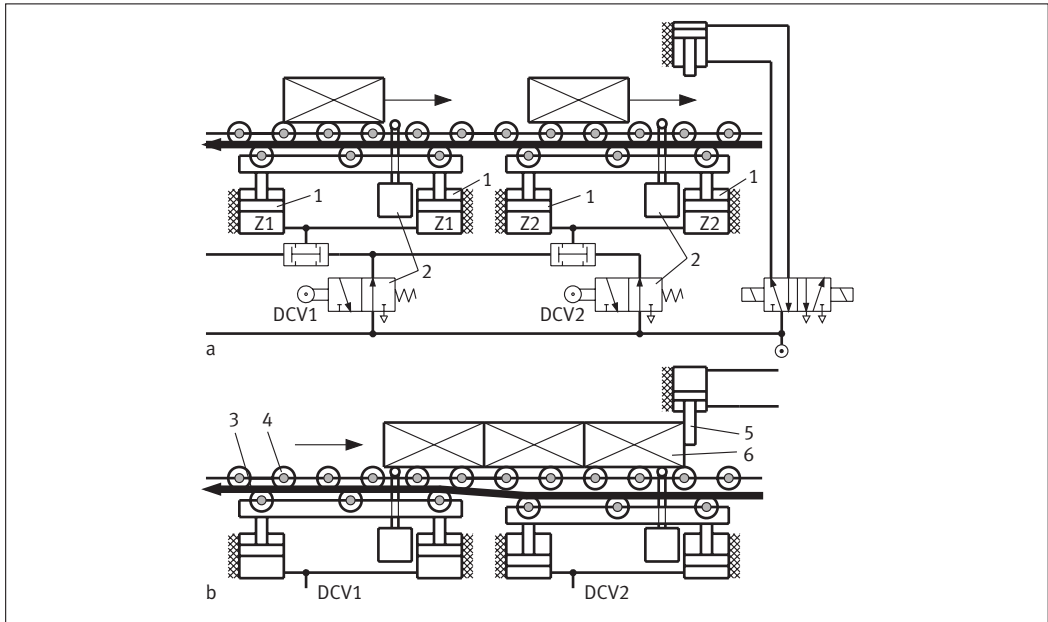

Accumulator conveyor

- a) Continuous throughput
- b) Accumulation

- 1 Pneumatic cylinder
- 2 Roller lever valve
- 3 Drive belt
- 4 Support roller
- 5 Stopper cylinder
- 6 Conveyed material

Accumulator conveyors react to accumulations of conveyed material. In the case of a roller conveyor, for example, the reaction is to disconnect drive to the conveyor section where an accumulation is present. The drive belt runs continuously and is pressed against the support rollers, causing these to rotate. The conveyor is divided into sections, frequently with a length of 2.5 m, each of which is equipped with a 3/2-way valve with a roller actuator. These valves act via pneumatic timers (throttles) and AND gates to control the lifting cylinders. The cylinders in a given section are pressurised only when the two directional control valves DCV1 and DCV2 are both actuated. When DCV2 is depressurised, a compressed air supply is switched to the cylinders Z2, thus restoring drive to this conveyor section. Even light workpieces (empty containers) are able to activate the drive force, which means that gaps between workpieces are eliminated. The entire conveyor can be operated as one accumulation zone if required.

Suitable components:

- Stopper cylinder STA...
- 5/2-way single solenoid valve M...
- Compact cylinder ADVU...
- Mounting accessories
- Roller lever valve R-3...
- Fittings
- AND gate ZK...
- Proximity switch SM...

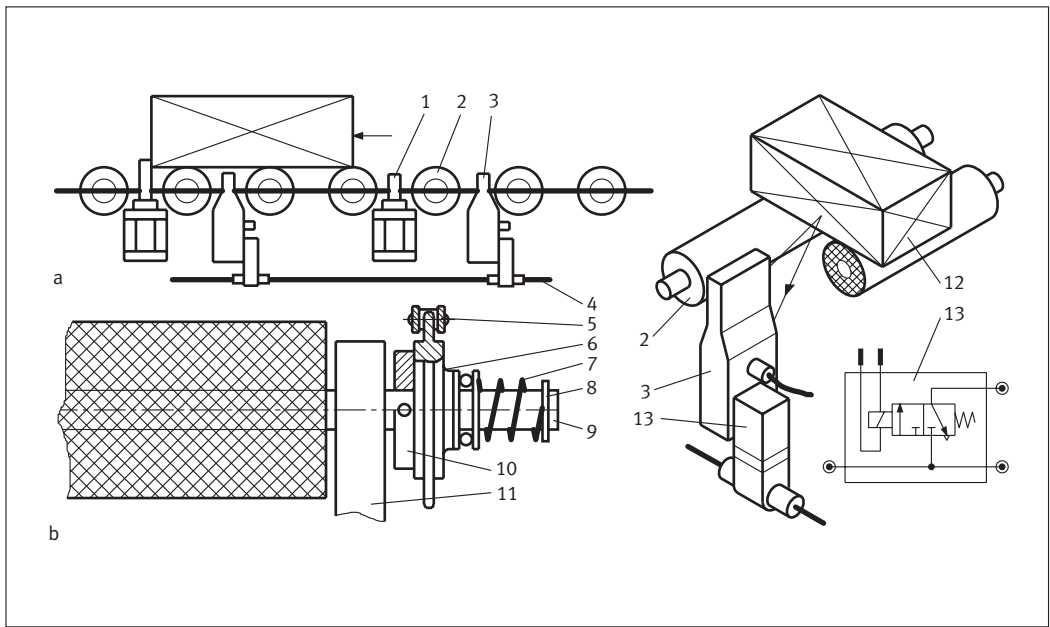

Sensor-controlled accumulator conveyor

- a) Arrangement of sensors
- b) Roller drive with slipping clutch

- 1 Stopper cylinder
- 2 Roller conveyor
- 3 Sensor valve
- 4 Compressed air supply line
- 5 Drive chain
- 6 Sprocket
- 7 Pressure spring
- 8 Circlip
- 9 Axis
- 10 Driver disc, friction operated
- 11 Frame
- 12 Conveyed material
- 13 Pneumatic single pilot valve

In this example, specially developed sensor valves are used to control the conveyed material on accumulator conveyors. Optical reflex sensors with electronic background filters and pneumatic directional control valves are combined in each case into a unit which can easily be installed in the spaces between conveyor rollers. This allows the activation, for example, of stopper cylinders, which halt the flow of conveyed material in one conveyor section after another. With a frictional connection of the conveyor roller and roller drive via a chain (Fig.b), the rollers will then stop. If motorised rollers are used, these can be switched off in the appropriate section while the accumulation persists. The valves are equipped with manual overrides. With roller conveyor widths of 350 to 500 millimetres, the sensors should be installed with a slight inclination towards the support roller axis. These sensor valves could, by the way, also be used to good effect in example 26.

Suitable components:

- Stopper cylinder STA...
- Proximity switch SM...
- Sensor valve SOV...
- Power supply module SOV-Z-EM
- Pneumatic single pilot valve...
- Mounting accessories
- Fittings

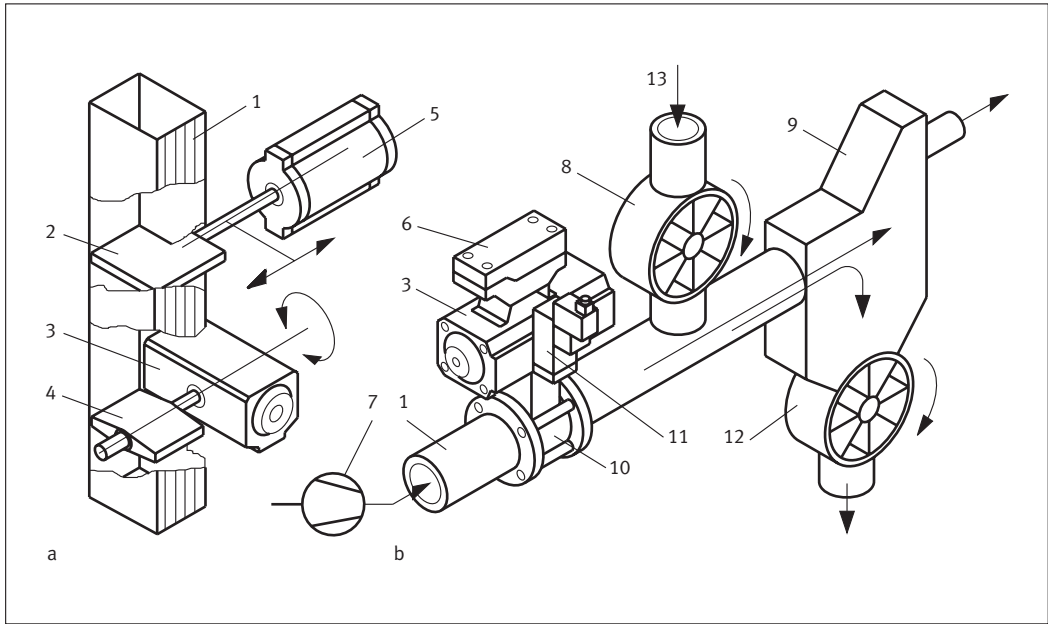

Conveying bulk material

- a) Pressure vessel lock with combined slide/flap
 b) Pneumatic pressure conveyer system

- 1 Pipe
- 2 Flat slide
- 3 COPAR semi-rotary drive
- 4 Swivel flap
- 5 COPAC linear actuator
- 6 Limit switch box
- 7 Compressed air fan
- 8 Bucket wheel intake
- 9 Hopper
- 10 Swivel slide unit
- 11 NAMUR valve
- 12 Bucket wheel discharge gate
- 13 Conveyed material inlet

Suitable shut-off valve systems, capable of being triggered electrically, hydraulically or pneumatically, are required in order to control the flow of material in large piping systems. The above example shows a possible use of linear and rotary shut-off devices. Material is conveyed pneumatically, i.e. it is carried by the flow of compressed air. The shut-off device following a pressure vessel is often required to operate continuously to shut off the flow of bulk material and provide a seal against pressure. As it is difficult to achieve both these functions with one device, they are provided by two separate devices in Fig. a. First the flat slide shuts off the flow of bulk material, and then a swivel flap seals the pipeline against pressure. Among the bulk materials for which a system of this kind can be used are granulates, machining chips, dust, minced meat, oats, basic chemicals, animal feedstuffs, ash, slag, powders, aggregates, cement, fishmeal, etc. The most important factor is that the material in question must have appropriate flow characteristics.

Suitable components:

Semi-rotary drive COPAR, DR...
 Linear drive COPAC, DLP...
 Rod eye SGS...
 NAMUR valve M...
 Proximity switch SM...
 Mounting accessories
 Fittings

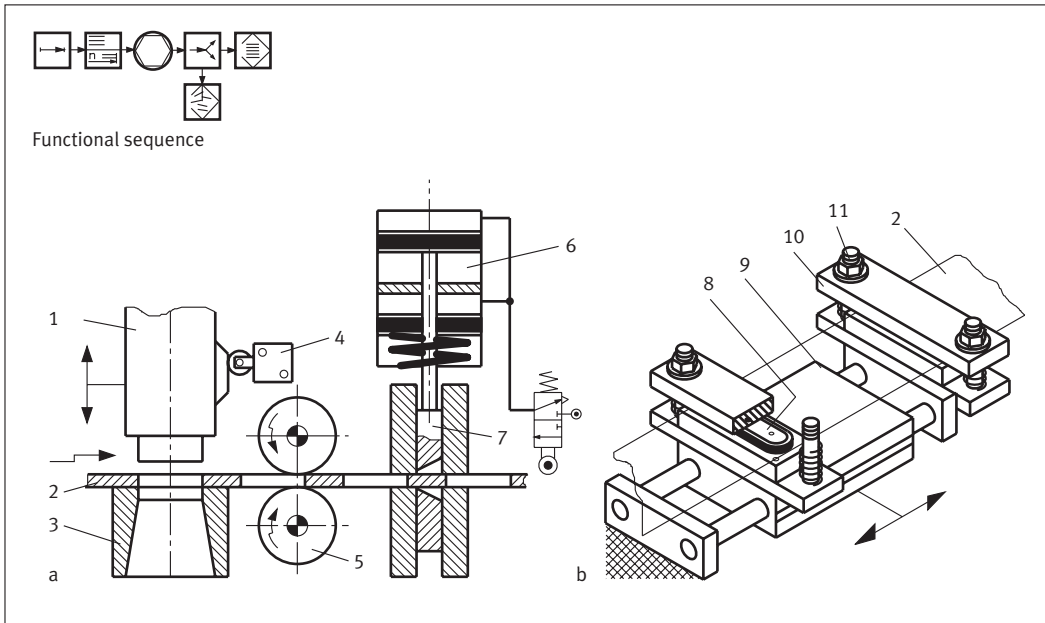

Pneumatic waste cutter

- a) Principle of waste material cutter
 b) Pneumatic feed unit

- 1 Press ram with blanking punch
- 2 Strip of material
- 3 Lower part of tool
- 4 Electrical feeler
- 5 Pair of conveyor rollers
- 6 Pneumatic cylinder
- 7 Cutter blade
- 8 Pressure piece
- 9 Linear unit
- 10 Clamp plate
- 11 Strip thickness adjustment

With certain presses, for example hydraulic ones, it is not possible to derive an auxiliary motion by mechanical means. In these cases, pneumatic drives are a good alternative. In the application shown above, workpieces are punched out of strip material and it is then necessary to cut the remaining lattice-like waste material into pieces. The pneumatic drive selected should be capable of completing the cutting operation with adequate reserve power. Furthermore, the cutting blade should be inclined to one side of the production line to produce an oblique cut over a greater distance. This reduces the cutting force required (although not the cutting work). If the press in question is not equipped with roller feed, this can also be carried out by pneumatic means, using a combination of diaphragm pressure units and a linear unit. The diaphragm pressure units are of very flat design and are advanced alternately in an advance/return rhythm. Pneumatic components are a highly suitable means of retrofitting devices of this kind to existing systems.

Suitable components:

Twin cylinder ADVU...
 Linear unit DPZ]...
 Proximity switch SM...
 Pneumatic single pilot valves...
 Roller lever valve RIO...
 Clamping module EV...
 Mounting accessories, Fittings

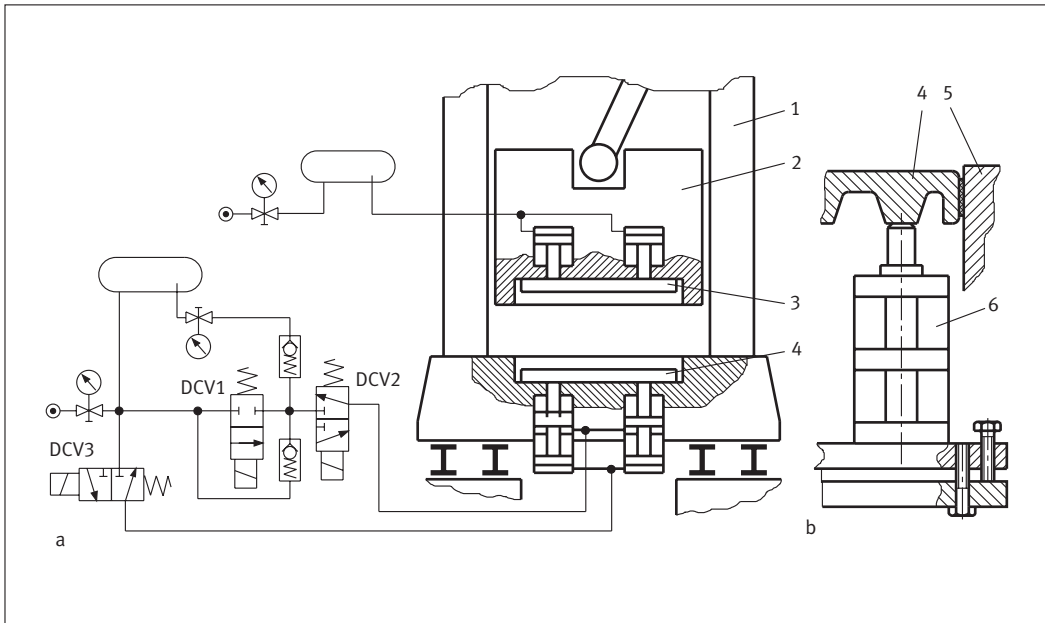

Pneumatic die cushion

- a) Design principle
b) Cylinder installation

- 1 Press frame
2 Press ram
3 Passive die cushion
4 Active die cushion
5 Press table
6 Pneumatic cylinder

In order to be able to carry out the drawing work on a single-acting press in the same way as a double-acting press, the press must be equipped with a pneumatic die-cushion. These are available in the form of unactuated (die-cushion in the ram in the example) and actuated die-cushion (in the press table in the example). The latter is actuated at the appropriate time by a signal generated by the press crankshaft or by the cams of the respective control units.

Actuated cushion drawing with ejection: When the ram meets the die-cushion, this causes the cushion to be partially pressurised via DCV2. As the drawing process continues, the cylinders are supplied with half or full pressure via DCV1 and DCV3. Ejection then takes place at bottom dead centre, actuated by DCV2.

Operation via unactuated cushion drawing: DCV1 is closed and DCV2 and DCV3 are open.

Controlled ejection: After the ram has been raised, the die-cushion is partially pressurised via DCV2 to allow ejection of the finished drawn workpiece and is depressurised again after the ram has come to a halt at top dead centre.

Suitable components:

Compact cylinder AEVU...

Proximity switch SM...

Twin cylinder ADVUT...

Non-return valve HGL...

Compressed air reservoir VZS...

3/2-way valve...

2/2-way valve...

Mounting accessories

Fittings

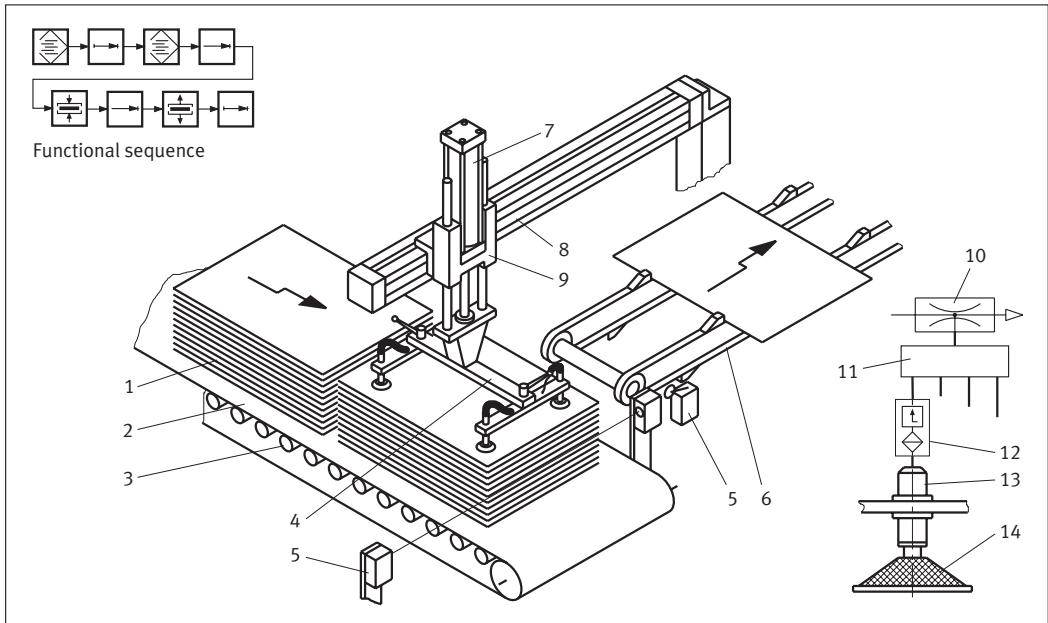

Destacking device for panels

- 1 Stack of panels
- 2 Conveyor belt
- 3 Support roller
- 4 Suction extractor arm
- 5 Sensor
- 6 Indexed conveyor belt
- 7 Pneumatic cylinder
- 8 Rodless linear drive
- 9 Guide
- 10 Vacuum generator
- 11 Distributor
- 12 Vacuum efficiency valve
- 13 Height compensator
- 14 Suction cup

On production lines, for example for furniture components, it is necessary to lift chipboard, plastic, plywood and hard fibreboard panels from stacks and place these on a conveyor belt. This can be carried out effectively using vacuum suction cups, provided that the material in question is not excessively porous. In this example, a continuous conveyor is used to bring the stack to the transfer point, at which it is halted by a sensor signal. The number and size of suction cups used will be governed by the weight of the workpieces. The suction cups are spring-mounted to compensate for minor height differences (up to 5 mm).

Suitable components:

Standard cylinder DNC... with guide unit FEN... or SLT...
 Vacuum generator VAD...
 Pneumatic single pilot valves or valve terminal CP...
 Distributor block FR...
 Pneumatic linear drive DGPL...
 Height compensator VAL...
 Proximity switch SME...
 Through-beam sensor SOEG...
 Mounting accessories
 Suction cup VAS...
 Sensor
 Vacuum efficiency valve ISV...

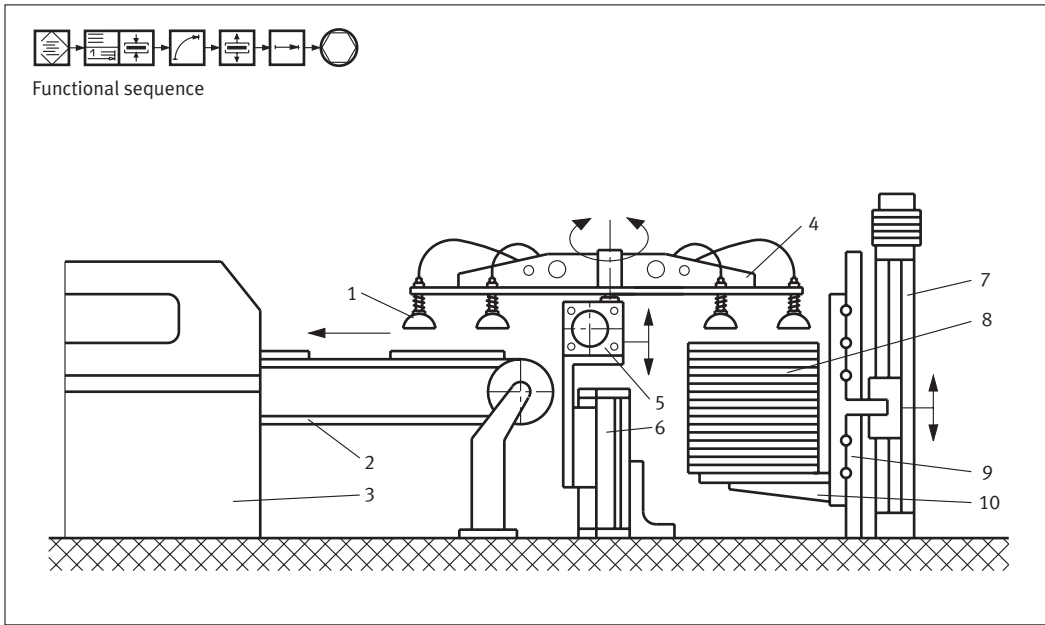

Rotary feeder for panels

- 1 Suction cup
- 2 Conveyor belt
- 3 Machine tool
- 4 Swivel arm
- 5 Rotary drive
- 6 Lifting drive
- 7 Electromechanical spindle lifting unit
- 8 Stack of panels
- 9 Linear guide
- 10 Lifting platform

In the example, a machine tool is fed with working material in panel form. The suction cups are fitted to a double arm, thus allowing pick-up and set-down operations at the same time. Parallel actions of this kind save time. The stack of working material is raised in stages, giving a reasonably constant pick-up height. The suction cups should be spring-loaded. One disadvantage of this solution is that the machine tool is not fed with workpieces during the loading of the lifting platform. This downtime is the result of the return time of the empty platform and the time required for reloading. If this downtime is not acceptable, a twin stack lifting unit must be provided.

Suitable components:

Pneumatic linear drive DGPL... or SLT...
 Pneumatic single pilot valves VL...
 Linear axis DGE...
 Sensor
 Mounting accessories
 Rotary drive DRQ

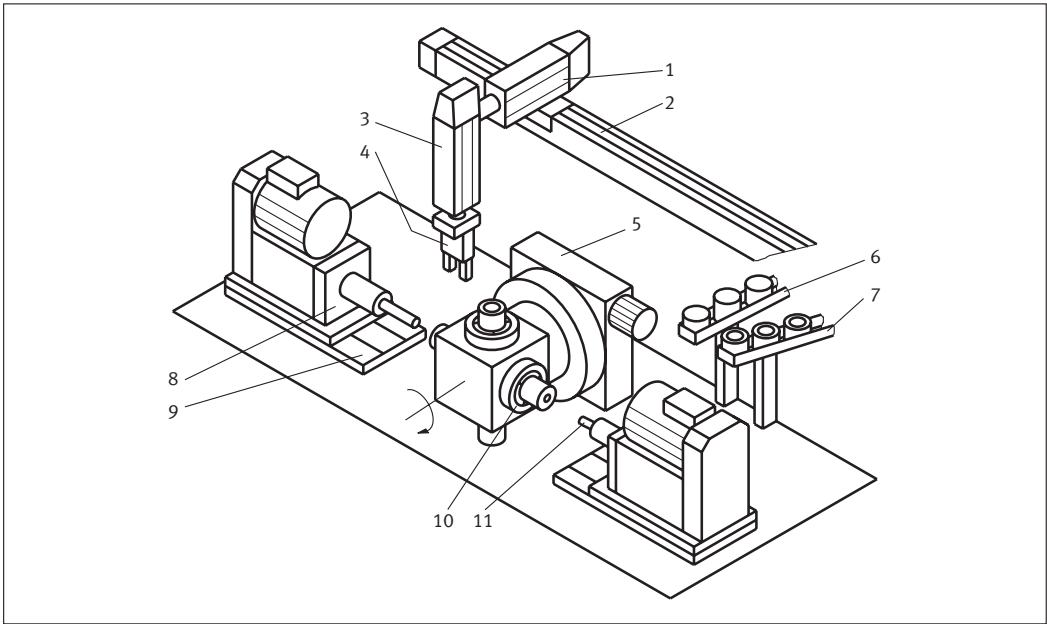

Special drilling unit

- 1 Linear module
- 2 Rodless pneumatic cylinder
- 3 Vertical unit
- 4 Parallel-jaw gripper
- 5 Pneumatic rotary indexing table
- 6 Feeding of unmachined blanks
- 7 Chute for finished workpieces
- 8 Spindle unit
- 9 Linear feed unit
- 10 Pneumatic chuck
- 11 Tool

The drilling, countersinking and chamfering of small workpieces in medium-sized and large batches are typical work operations in mechanical engineering. It can be well worth while to develop special devices for these operations. In this example, the workpiece carriers consist of high-powered pneumatic chucks which are indexed about a horizontal axis with the aid of a rotary indexing table. Pneumatic pick-and-place units are used for loading and unloading. If the device is used on a drilling/milling machine with a vertical working spindle, a further working operation can be carried out in the loading position. A hydraulic cushioning cylinder can be connected up in parallel to cushion the feed motion.

Suitable components:

- Pneumatic chuck
- Pneumatic single pilot valves VL... or valve terminal CP... or Valve terminal Type 03
- Linear unit SLZ...
- Hydraulic cushioning cylinder YDR...
- Linear module HMP...
- Parallel gripper HGP... or 3-point gripper HGD...
- Rodless linear unit DGPL...
- Proximity switch SM...
- Pneumatic rotary indexing table

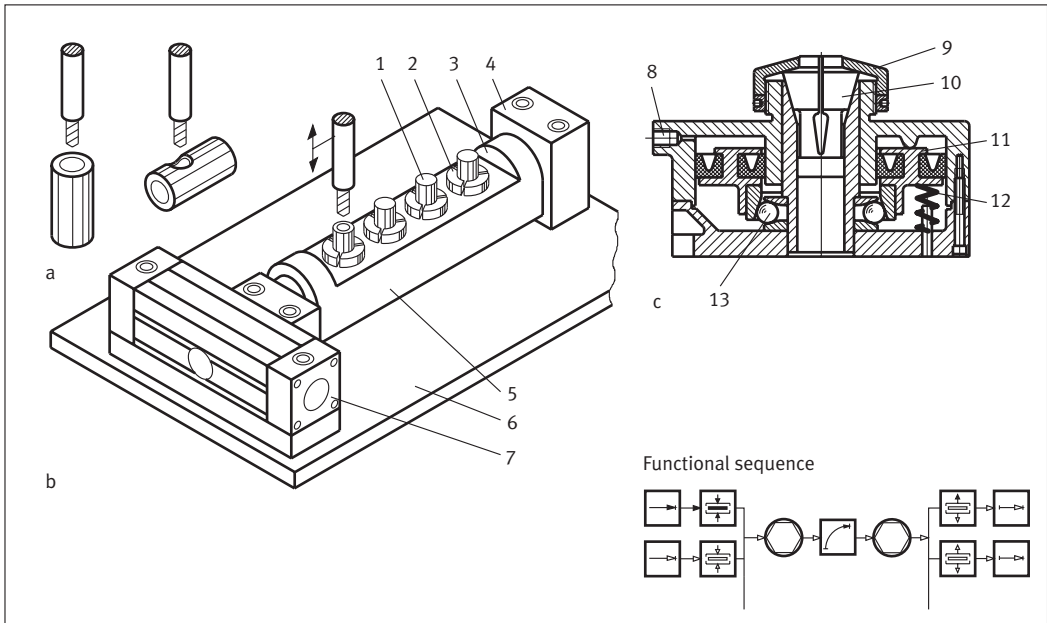

Device for drilling on 2 planes

- a) Machining operation
- b) General view
- c) Pneumatic chuck

- 1 Workpiece
- 2 Pneumatic chuck
- 3 Clamping component mounting surface
- 4 Clevis foot mounting
- 5 Basic body
- 6 Base plate
- 7 Rotary drive
- 8 Compressed air supply
- 9 Lock nut
- 10 Clamping collet
- 11 Piston
- 12 Return spring
- 13 Ball to transmit clamping force

Multiple workpiece clamps have the advantage that auxiliary process time can be saved. The illustration shows a device in which several high-power collect chucks are mounted on a tiltable carrier. The chucks are pneumatically operated and generate clamping forces of up to 70 kN at a pressure of 6 bar. Drilling is carried out on 2 planes. The axial holes are first drilled, and the workpiece is then swivelled through 90° to allow the radial holes to be drilled. For very precise work, it is possible to provide an additional pneumatic cylinder to index the workpiece by means of a tapered pin (at the side or underneath). The sectional view through the clamping collet shows that an enormous force-amplifying effect is obtained by feeding the motion of the annular piston through a bevel gear unit. Collet chucks are very robust clamping devices.

Suitable components:

- Pneumatic chuck
- Proximity switch SM...
- Compact cylinder (for indexing) ADVU...
- Pneumatic single pilot valve VL...
- Rotary drive DRQ... or DRQD...
- Foot mounting HQ...
- Mounting accessories

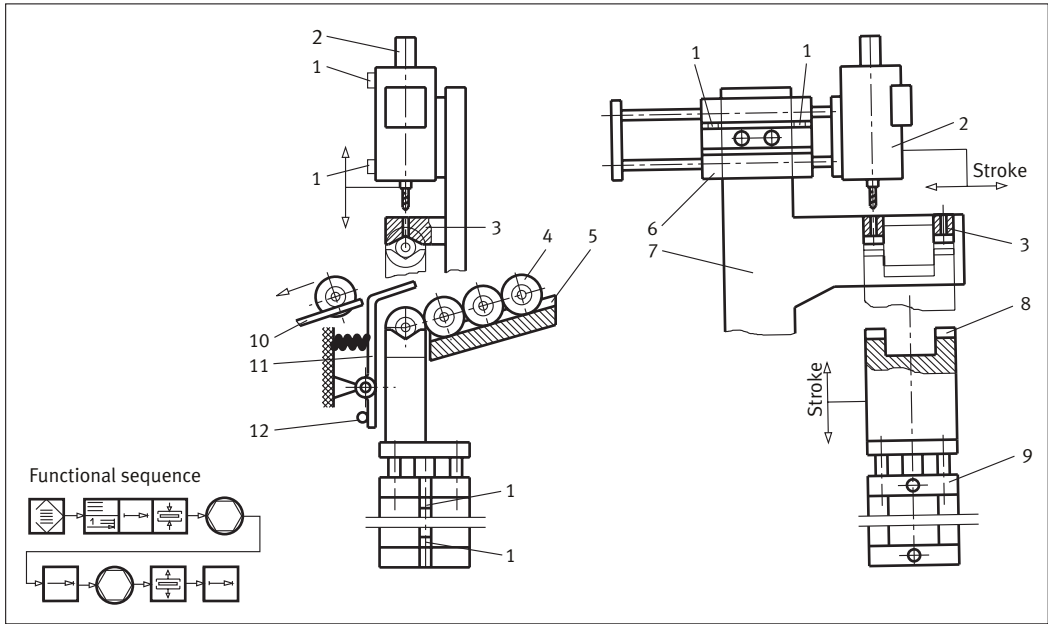

Drilling device for lateral drilling of round workpieces

- 1 Proximity sensor
- 2 Drill/feed unit
- 3 Drill guide
- 4 Workpiece
- 5 Roller conveyor
- 6 Linear unit
- 7 Frame
- 8 V-clamp/feed
- 9 Lifting and clamping cylinder

This device is used to produce two radially drilled holes with one clamping position. The workpieces are previously machined on an automatic lathe and are then placed in a roller conveyor magazine. They roll into a V-clamp which remains in its lowest position for this purpose. After this dwell time (delayed switching command), the workpiece is clamped and the first hole is drilled. The drilling unit then moves to the second drilling position. The two end positions of the linear unit are adjusted in such a way as to provide the separation distance called for in the workpiece drawing. The V-feed and clamp device now travels downward again. The workpiece is held by a spring-loaded detent and is able to roll away when the V-feed and clamp device reaches its lowest position. It passes along a rollway to a finished-workpiece container. The sequence is controlled by signals from cylinder switches and sensors.

Suitable components:

- Linear unit DPZJ...
- Pneumatic single pilot valve VL..., if appropriate also single solenoid valve MFH...
- Proximity switch SM...
- Compact cylinder ADVUL...

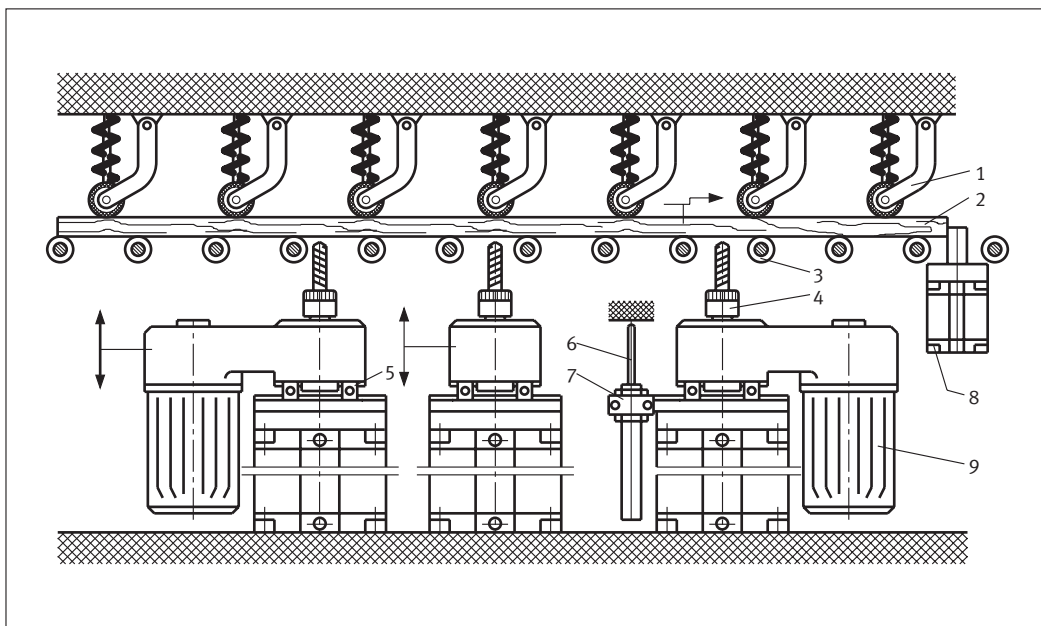

**Drilling of dowel holes
in furniture components**

- 1 Roller pressure device
- 2 Workpiece
(furniture panel)
- 3 Roller conveyor
- 4 Drilling unit
- 5 Clamp
- 6 Hydraulic cushioning
cylinder
- 7 Holder
- 8 Stopper cylinder
- 9 Drill motor

If panels used in the woodworking and furniture-making industries are drilled from underneath, the drill swarf can be removed easily. A drilling station operating on this principle is shown in the illustration. All that is required for the feed operation is a pneumatic short-stroke unit which carries the drilling unit. A clamp mounting allows subsequent correction of position. The feed motion can be made smoother by exploiting the effect of a hydraulic cushioning cylinder operating in the feed direction. The return stroke can be executed at high speed. During drilling, a roller pressure device and the weight of the panel itself act against the force of the drill bit(s). The panel is halted by a stopper cylinder as it runs into the machine. It may also be necessary to align the panel against a fixed corner stop and possibly also to clamp it in this position.

Suitable components:

- Compact cylinder ADVUL... or guide unit DFM...
- Pneumatic directional control valve VL...
- Hydraulic cushioning cylinder YDR...
- Proximity switch SME...
- Mounting flange YSRF...
- Stopper cylinder STA...
- Mounting accessories

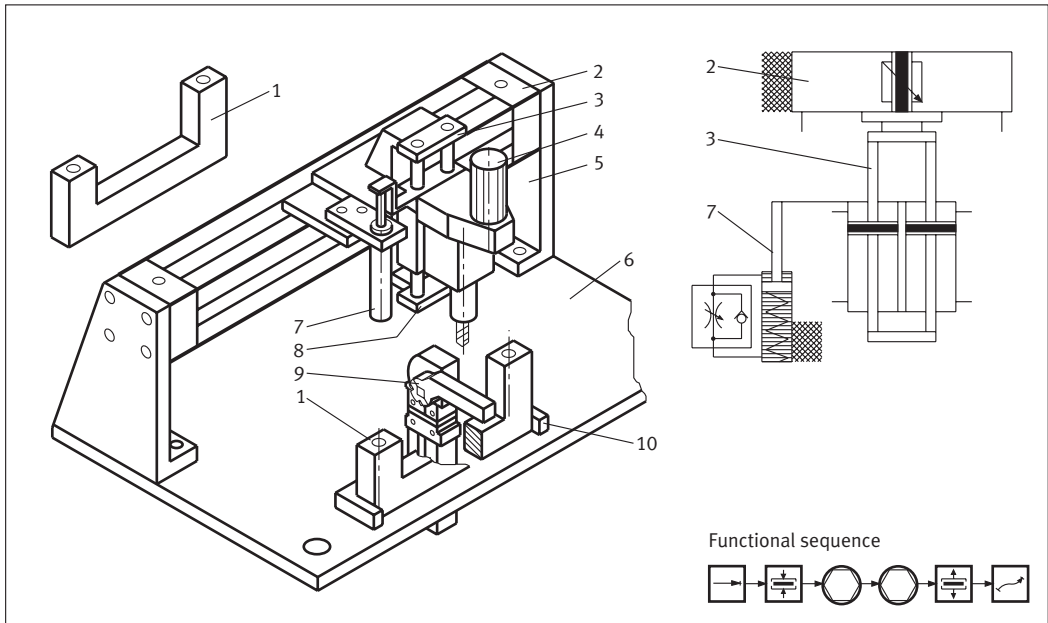

Drilling device for V-shaped workpieces

- 1 Workpiece
- 2 Rodless linear unit
- 3 Yoke with frame mounting
- 4 Drill motor
- 5 Stand
- 6 Base plate
- 7 Hydraulic cushioning cylinder
- 8 Vertical unit
- 9 Toggle-lever clamping system
- 10 Workpiece carrier

In the case of this drilling device, the workpieces are inserted and removed manually and are held by a toggle-lever clamping system. After the first hole has been drilled, the drilling unit travels to the second position. The feed motion of the drilling unit is damped by a hydraulic cushioning cylinder. This device features a very high proportion of commercially available components. It can thus be assembled without any detailed design work. One worker can operate several devices of this or a similar type. The devices can also be used for testing or labelling operations.

Suitable components:

- Rodless linear unit DGPL...
- Mounting accessories
- Pneumatic directional control valves VL...
- Mounting flange YSRF...
- Toggle-lever clamping system CTLF...
- Hydraulic cushioning cylinder YDR...
- Proximity switch SME...
- Linear unit DPZ]...
- Safety start block for two-handed operation

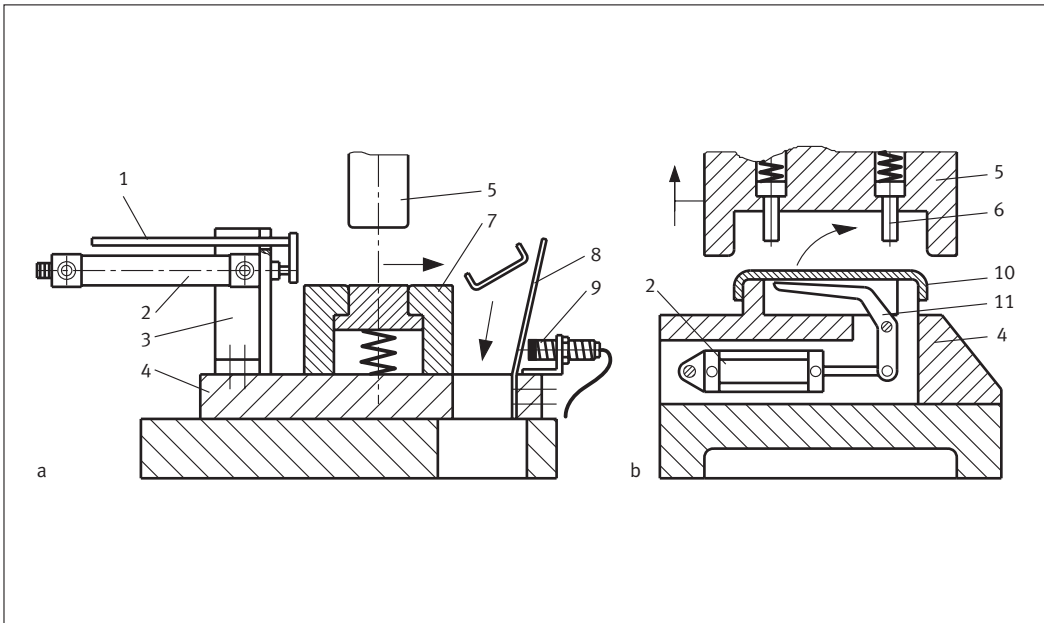

Ejector device for sheet-metal workpieces

- a) Slide ejector
b) Oscillating-lever ejector

- 1 Ejector slide
- 2 Pneumatic cylinder
- 3 Mounting bracket
- 4 Device baseplate
- 5 Bending ram
- 6 Push-off pins
- 7 Bending die
- 8 Catch plate
- 9 Sensor for ejector monitor and counter
- 10 Bending workpiece
- 11 Oscillating lever

In forming technology, workpieces are ejected automatically (for example, after bending or deep drawing). The illustration shows two examples of this. If workpieces are to be ejected by sliding, this requires them to have a smooth underside after the work operation in question. If this cannot be ensured, an arc-shaped ejection motion should be used. The pneumatic cylinders accordingly produce an ejection motion by acting either directly or indirectly via an oscillating lever. The immediate action produced by pneumatics is advantageous in this application, since this generates sharp acceleration of the workpieces without the need for the pneumatic cylinder concerned to be very large. This can accordingly in most cases be installed in or on the lower part of the tool. In certain cases, it may be sufficient to use an air jet as a workpiece ejector.

Suitable components:

Round cylinder DSEU...
Pneumatic single pilot valve VL...
Proximity switch SME...
Inductive sensor SIEN...
Flat cylinder DZH...
Swivel flange SZSB...
Rod eye SGS...
Mounting accessories

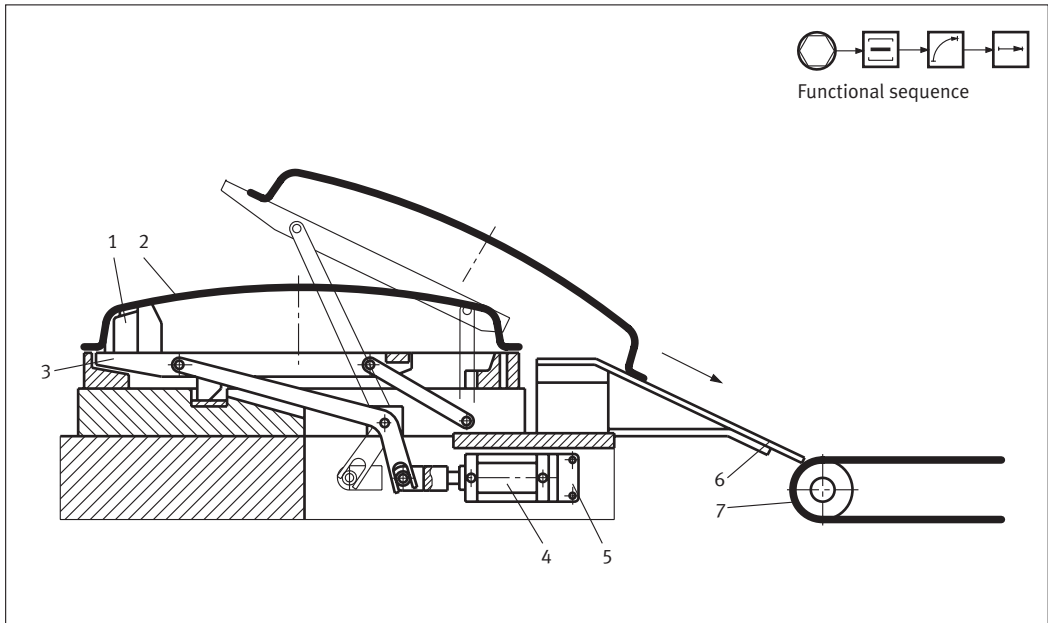

Lever ejector for deep-drawn and cut workpieces

- 1 Lower part of punch tool
- 2 Shaped sheet-metal workpiece
- 3 Coupling gear
- 4 Pneumatic cylinder
- 5 Foot mounting
- 6 Slide plate
- 7 Conveyor belt

The illustration shows the loading of a tool, for example for a combination of edge trimming and hole punching. The free space within the lower part of the tool has been used to install a lever mechanism that lifts the workpiece out of the tool and allows it to slide away to one side. A conveyor belt then takes up the workpieces and carries these to the next press or to a set-down point.

The coupling gear is driven by a pneumatic cylinder. The ejection operation is triggered by a sensor which monitors the ram stroke of the press or by a switch installed on the press drive mechanism (control shaft, centre shaft). An increasingly popular solution is to use a pneumatic handling unit with several circular or oval suction cups which travels into the tool zone, lifts out the workpiece and withdraws it laterally to a stacking point. This type of solution is however, more expensive than a simple lever ejector.

Suitable components:

Standard cylinder DNC...
 Foot mounting HNC...
 Rod clevis SG...
 Pneumatic single pilot valve VL...
 Proximity switch SME...
 Mounting accessories

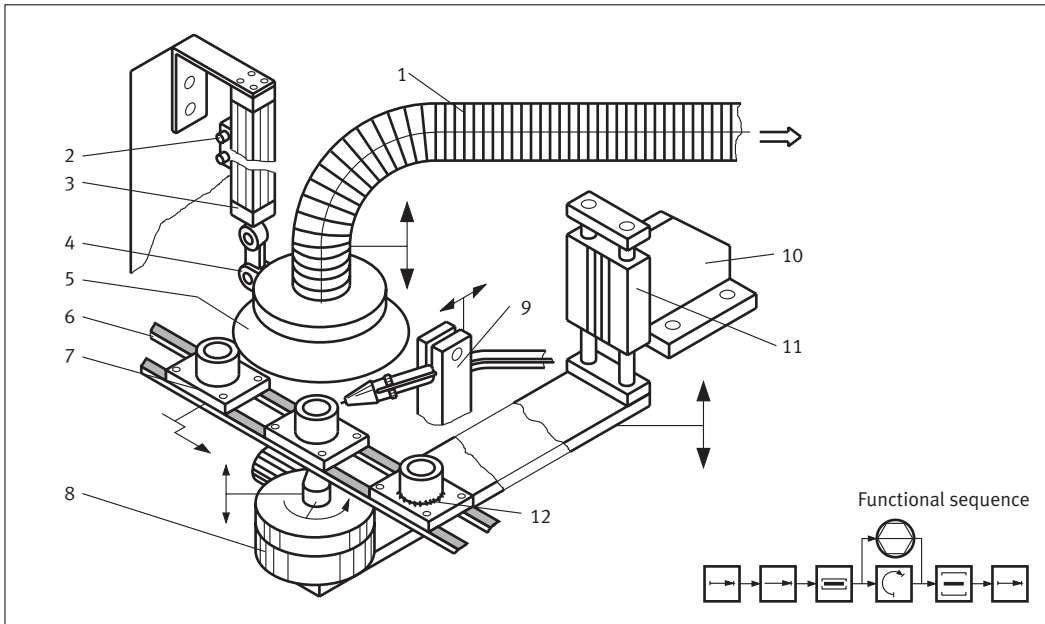

Brazing station with suction arm to extract hazardous substances

- 1 Suction hose
- 2 5/3-way directional control valve
- 3 Pneumatic cylinder
- 4 Connector joint
- 5 Shield
- 6 Transfer system
- 7 Base workpiece
- 8 Rotary unit
- 9 Burner holder
- 10 Frame
- 11 Linear unit
- 12 Brazed assembly

Suction extractor arms have the task of removing as efficiently as possible, air laden with hazardous substances (smoke gases, vapours, dust or paint spray) from the point at which these substances are released. The example shows the brazing of bushes. In the workstation, the workpiece assembly is lifted from the conveyor belt and turned at working speed through 360°. During this time, the suction shield is lowered pneumatically to a point close to the emission point. The shield is lifted again before the workpiece assembly is moved on to allow freedom of movement. Depending on the size and weight of the suction extractor device, it may be necessary to consider whether an additional linear guide is necessary or whether the lateral forces acting on the piston rod are still within the permissible range.

Suitable components:

Standard cylinder DNC...
 5/3-way valve MFH...
 Rod clevis SG... and mounting attachments
 Proximity switch SME...
 Linear unit SPZ...

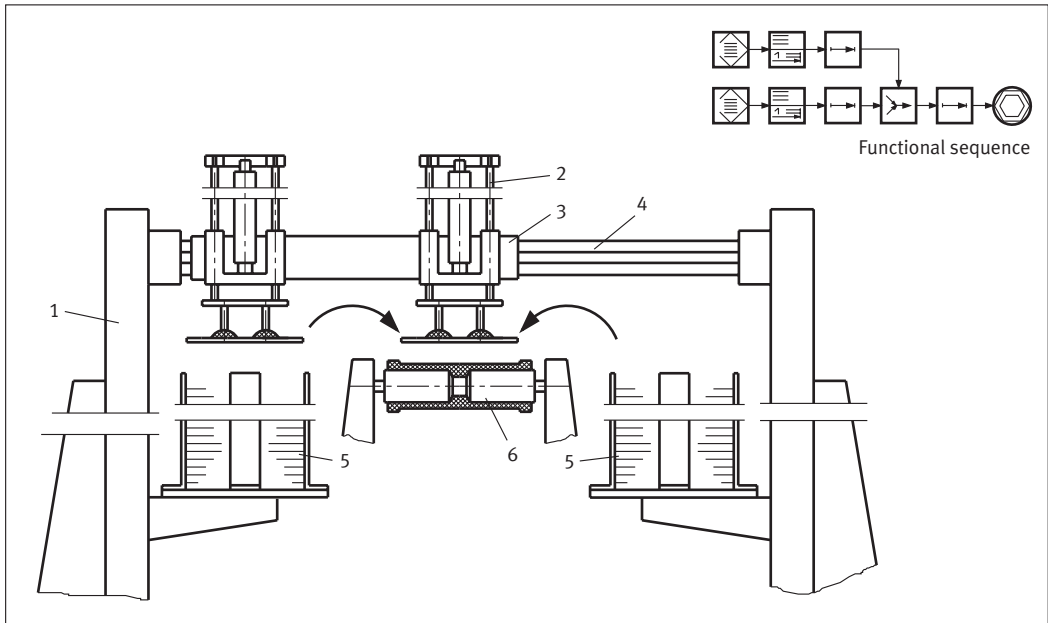

Alternate feeding of a production line

- 1 Frame
- 2 Pneumatic linear unit
- 3 Slide
- 4 Rodless linear unit
- 5 Magazine
- 6 Conveyor in-feed
to production line

In the case of devices for the surface treatment of workpieces, for example printing or the application of adhesive, workpieces must be placed on a conveyor belt in rapid succession. A normal pick-and-place cycle is frequently not able to achieve the desired level of performance. This example shows a solution to this problem in the form of rapid alternate feed from two magazines. This means that the setdown and magazine pick-up operations run simultaneously. The two vertical units used are mounted on a common slide. If very short cycle times are required, the horizontal unit can be a “Smart Soft Stop” axis, which allows time savings of up to 30% in comparison with standard pneumatic drives. If the conveyor belt is fitted with workpiece carriers into which the workpieces must be set down precisely, the motion of the feed system must be synchronised with that of the conveyor belt.

Suitable components:

Standard cylinder DSNU... with guide unit FEN... or drive unit DFM...
 Rodless linear unit DGPL... or Smart Soft Stop package with DGPL...
 with displacement encoder MLO-POT..., directional control valve MPYE-S-...
 and controller SPC-10
 Pneumatic single pilot valve VL... or valve terminal CP...
 Proximity switch SME...
 Suction cup VAS...
 Vacuum generator VAD...
 Vacuum efficiency valve ISV...

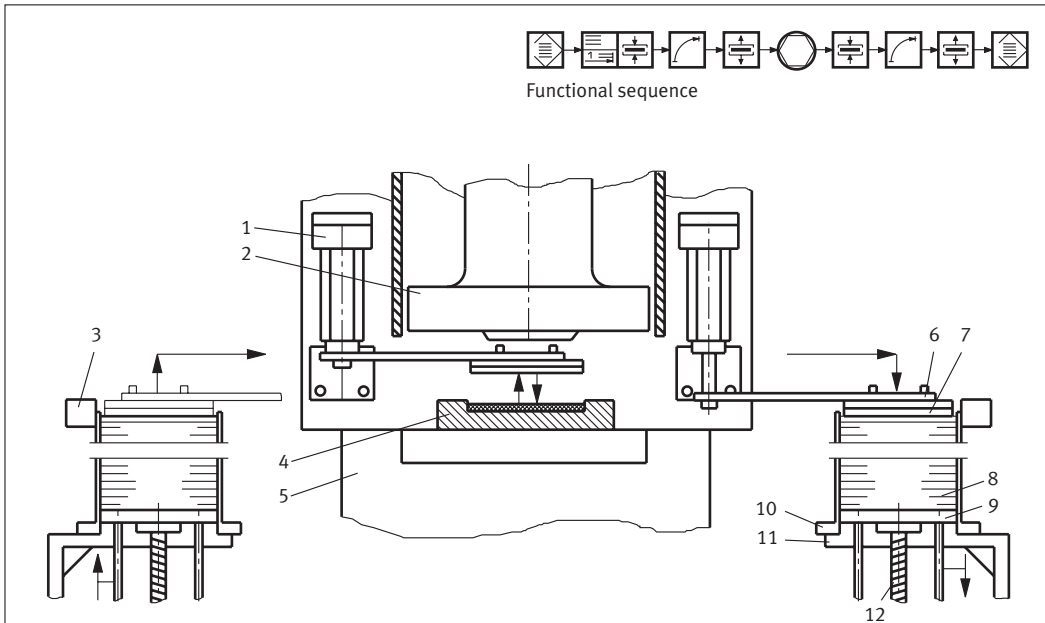

Feeding a press

- 1 Swivel/linear unit
- 2 Press ram
- 3 Level sensor
- 4 Lower part of tool
- 5 Press frame
- 6 Swivel arm
- 7 Suction plate
- 8 Workpieces (flat)
- 9 Lifting plate
- 10 Magazine body
- 11 Magazine frame
- 12 Lifting spindle

It is very often necessary to feed small flat workpieces, for example to allow further processing in a press (stamping, punching, notching, cutting to size, etc.). In order to allow the workpieces to be laid precisely into the tool, this example uses not individual suction cups but a suction plate that holds the workpieces perfectly level. This is particularly important with flexible workpieces. The insertion and removal operations are carried out by two swivel arms, each connected to a swivel/linear unit. The magazines are of active design; i.e. the contents are moved up or lowered by a spindle magazine. Sensors monitor the magazine levels and control the follow-up steps in real time. The infeed and outfeed sides are of identical design. If the infeed and outfeed operations are carried out by a single handling unit, it reduces production throughput, since simultaneous operations will then no longer be possible. The amount of technical work required, and the cost involved, will however be lower.

Suitable components:

Swivel/linear unit DSL..
 Shock absorber YSR..
 Pneumatic single pilot valve VL... or valve terminal CP..
 Proximity switch SME..
 Diffuse sensor SOEG..
 Vacuum generator VAD..
 Vacuum efficiency valve ISV..
 Mounting accessories

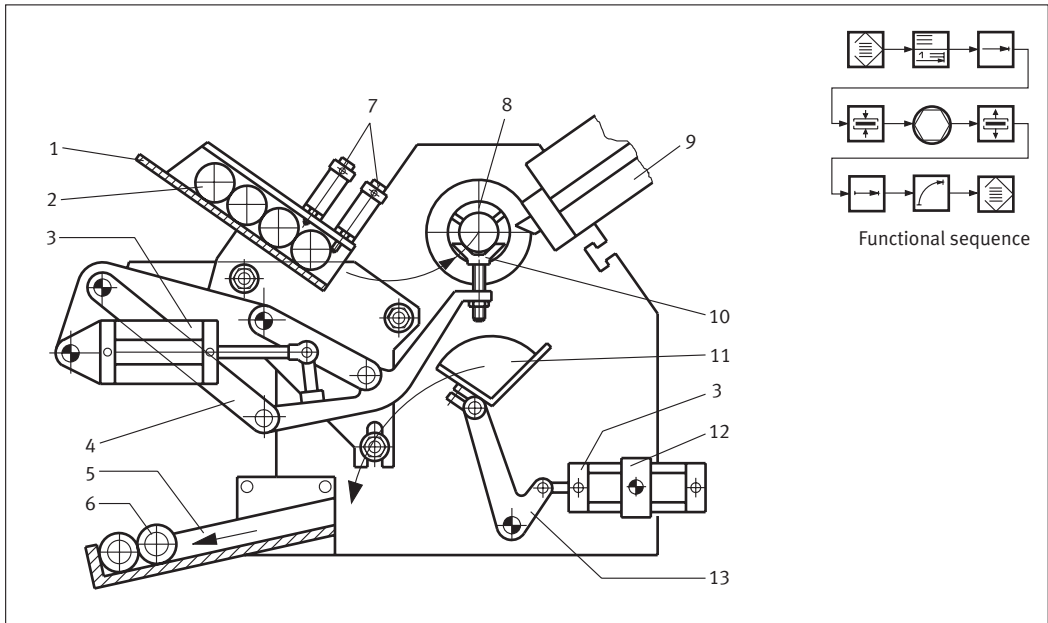

Magazine feed for an automatic lathe

- 1 Magazine for cylindrical workpieces
- 2 Workpiece (blank)
- 3 Pneumatic cylinder
- 4 Four-link mechanism (double rocker)
- 5 Outlet chute
- 6 Finished workpiece
- 7 Pneumatic cylinders for feed function
- 8 Collet chuck
- 9 Tool slide
- 10 Feed device
- 11 Removal device
- 12 Articulated joint
- 13 Angle lever

The illustration shows a solution for the feed and removal of round parts on an automatic lathe. A v-shaped height adjustable carrier accepts a blank workpiece from the magazine and lifts this to the centre of the chuck axis. In this position, it is pushed into the chuck by a ram (not shown). After machining, the finished workpiece falls into a tray which then tips towards an outlet chute. The entire device is mounted on a base plate and can be attached to prepared areas on machine tools. During machining, the workpiece-carrying components must be swivelled into a parking position out of the way of machining chips.

Suitable components:

Standard cylinder ESN...
 Standard cylinder DNG...or DNC...
 Proximity switch SM...
 Pneumatic cylinder
 Clevis foot mounting LBG...
 Rod eye SGS...
 One-way flow control valve GR...
 Trunnion support LNZ...
 Mounting accessories
 Fittings

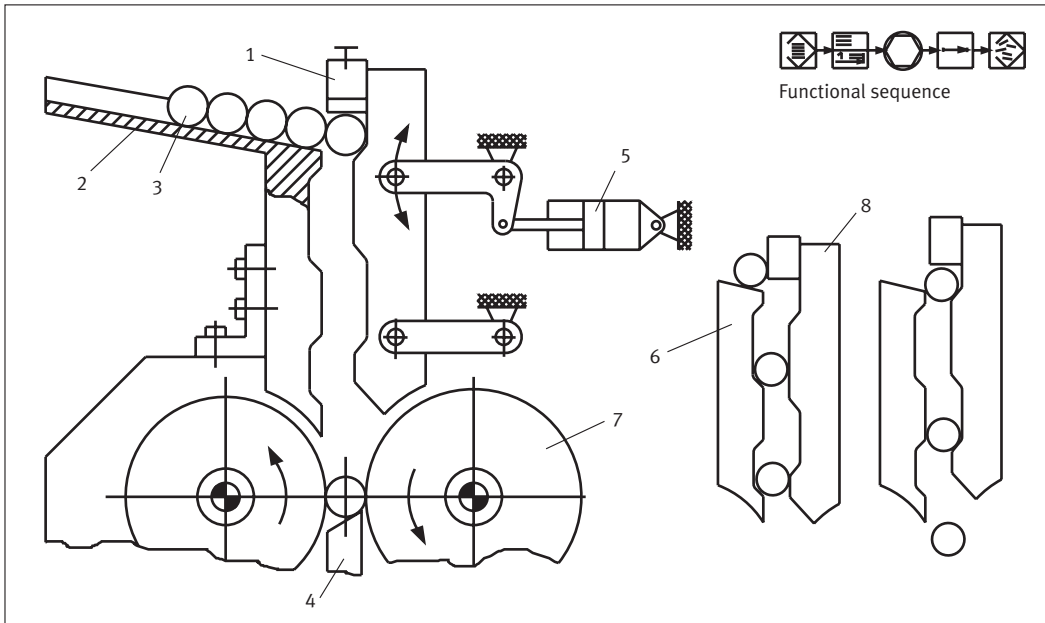

Feed device for a thread-rolling machine

- 1 Adjustable lifting stage
- 2 Roller conveyor magazine
- 3 Workpiece (blank workpiece for rolling)
- 4 Hardened support arm
- 5 Pneumatic cylinder
- 6 Fixed guide mechanism
- 7 Thread-rolling tool
- 8 Movable feed segment

Thread rolling is a very efficient non-machining forming process, and it is thus advantageous also to automate the entire feed process for the blank workpieces. The illustration shows a possible solution. The workpieces are transferred in an orderly way from a feed system to the roller conveyor magazine of the machine. The ingenious design of a movable feed segment has made it possible to carry out the feed operation with a single drive. The stepwise downwards motion means that the workpieces are able to orient themselves at each step and are perfectly level when they reach the support arm. The finished workpieces reach the collector bin by themselves, as they can be conveyed by the pitch of the thread which is produced. The principle of the feed device used here can also be adapted for use with shouldered workpieces and those with heads.

Suitable components:

Standard cylinder DNC...
 Proximity switch SM..
 Rod eye SGS...
 Clevis foot mounting LSNG...
 One-way flow control valve GR...
 Mounting accessories
 Fittings

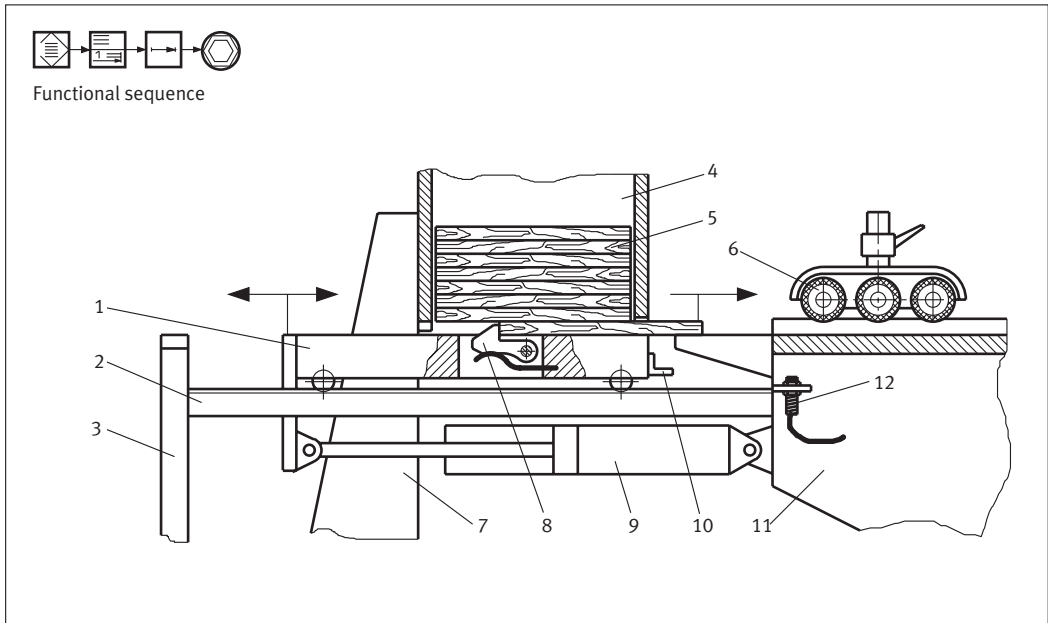

Feed system for a glue-applicator machine

- 1 Feed and input slide
- 2 Support rail
- 3 Stand
- 4 Magazine
- 5 Workpiece
- 6 Roller feed device
- 7 Magazine stand
- 8 Drive pawl
- 9 Pneumatic cylinder
- 10 Switch lug
- 11 Machine tool
- 12 Sensor

Modern feed technology pursues the objective of production with a low demand for human operators and aims at least to permit one operator to control several machines. A further objective is to speed up processes and provide better monitoring for these, since this may allow better exploitation of machine capacity. The illustration shows a simple feed device for flat strips or panels which can be retrofitted to an existing machine. The workpieces are removed from a magazine by a driver pawl (several pawls in the case of wide workpieces) and pushed forward to the roller feed device. This accepts the workpiece and pushes it under the tool (not shown) or onto the conveyor belt of a glue-applicator station. The feed device is equipped with rubber-covered rollers. It is sufficient if the driver pawl acts on the workpiece for just a few millimetres. The feed slide runs along V- or U-shaped rails until the switch lug trips the sensor and reverses the motion. This reversal can also be triggered by a proximity switch.

Suitable components:

Standard cylinder DNC...
 Rod eye SGS...
 Clevis foot mounting LSNG...
 Proximity switch SM...
 One-way flow control valve GR...
 Mounting accessories
 Fittings

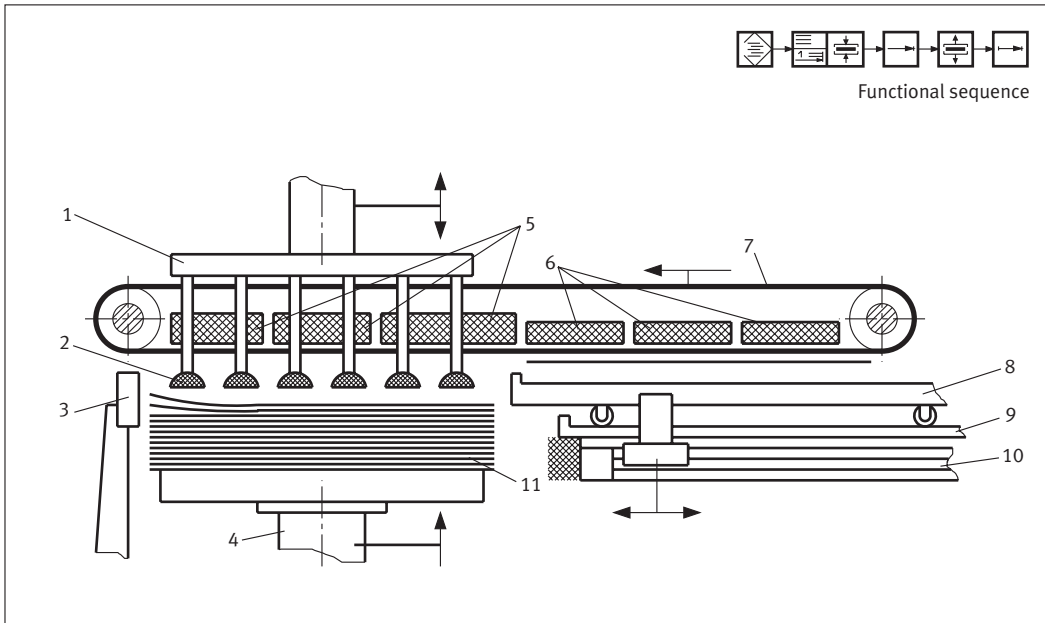

Feeding of sheet metal

- 1 Carrier plate for vacuum unit
- 2 Round suction cups
- 3 Spreader magnet
- 4 Lifting table
- 5 Permanent magnet
- 6 Switchable electromagnet
- 7 Conveyor belt
- 8 Loading table
- 9 Support rail
- 10 Rodless cylinder

The supply of deep-drawing presses requires sheets of metal to be brought one at a time to the tool. Ferromagnetic workpieces can be conveyed by a combination of vacuum and magnetic holding forces. In the solution shown above, the top workpiece is lifted from the stack by round suction cups. Multiple conveyor belts are used side by side; the suction cups are able to execute a vertical stroke in the gaps between the belts. When the workpiece has been fully raised, it is pressed magnetically against the conveyor belts and transported suspended. The permanent magnets are followed by a number of electromagnets, which are switched at the precise moment when the workpiece is exactly over the castor-mounted loading table. This causes the workpieces to fall onto the table, on which they can be moved into the tool area of the press. In order to prevent two workpieces from being picked up together, the edges of the upper workpieces are opened out slightly using spreader magnets.

Suitable components:

Rodless linear drive DPGL...
 Proximity switch SM...
 One-way flow control valve GR...
 Vacuum generator VAD...
 Vacuum efficiency valve ISV...
 Pneumatic cylinder...
 Suction cup VAS...
 Mounting accessories, Fittings

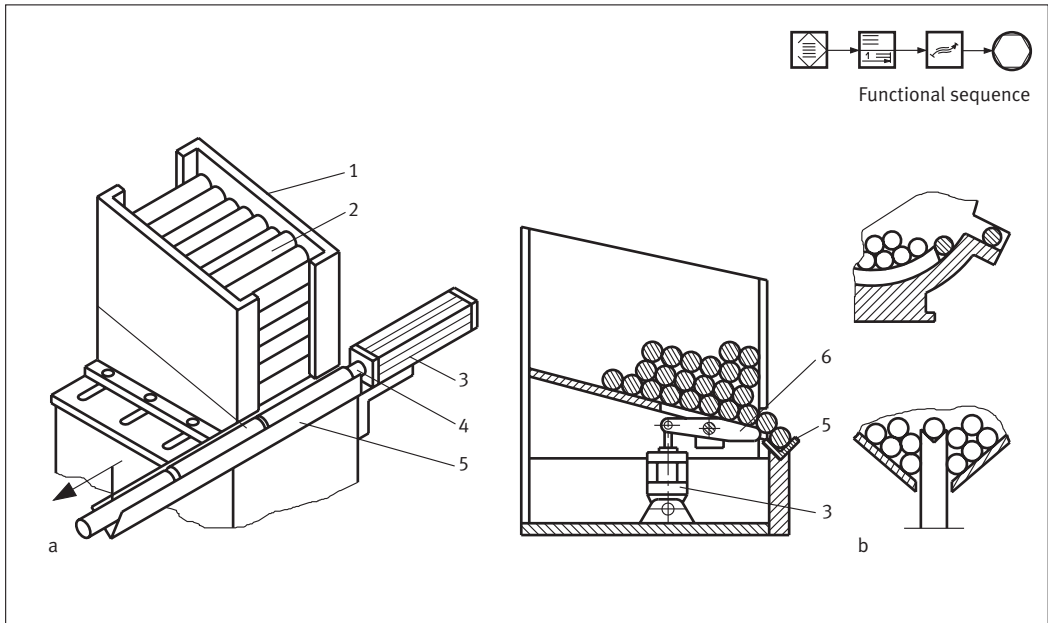

Feed magazine for rods

- a) Overall view
of feed magazine
b) Alternative solutions
with scoop segments

- 1 Stack magazine
- 2 Workpiece
- 3 Pneumatic cylinder
- 4 Piston rod
with pressure cap
- 5 Chute
- 6 Rocker lever

Assembly machines and machine tools may require supplying with rods, tubing sections etc. which should preferably be automatic. The illustration shows a stack magazine from which one workpiece is fed at a time. The magazine is adjustable for different workpiece lengths. The magazine outlet is fitted with a vibrator (rocker lever) which prevents jamming of the workpieces. There would otherwise be the risk that, due to frictional and weight forces, a number of workpieces would form a “bridge” which would prevent further progress. This feed device could, for example, be fitted to a centreless grinding machine. Instead of a gravity outlet, stack magazines can also be fitted with scoop elements (Fig. b). Scoop segments pick up one workpiece at a time from the magazine.

Suitable components:

Standard cylinder DNC...
Foot mounting HNC...
Proximity switch SM...
Pneumatic single pilot valve...
One-way flow control valve GR...
Compact cylinder ADVU...
Swivel flange SUA...
Rod eye SGS...
Mounting accessories
Fittings

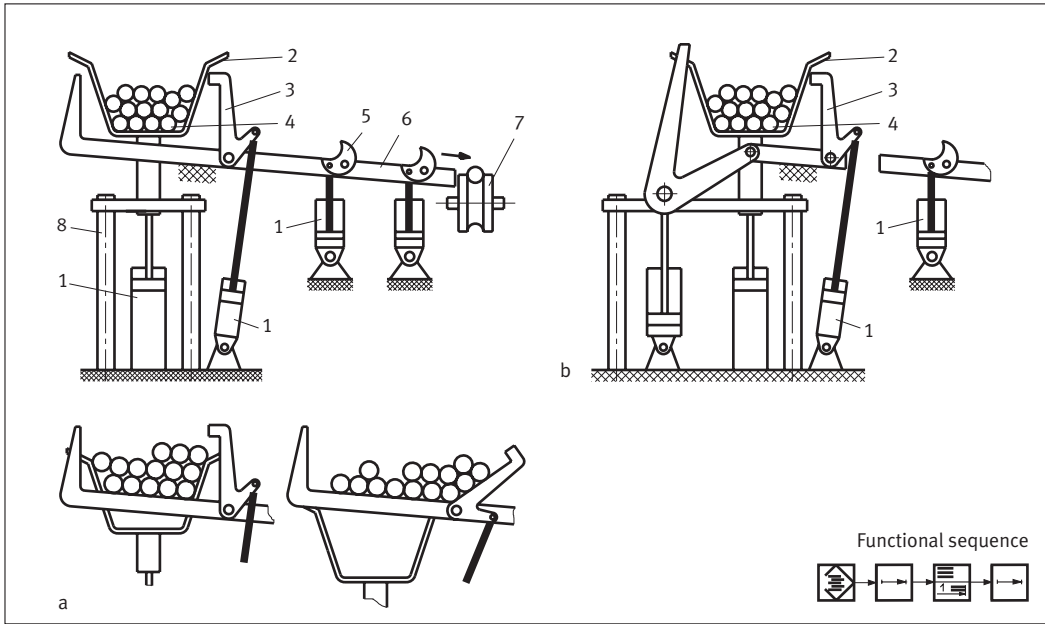

Feed system for rods

- a) Device with hold-back arm
b) Variant with 2 rocker arms

- 1 Pneumatic cylinder
2 Carrier trough
3 Hold-back arm
4 Working material
5 Release cam
6 Roller track
7 Roller conveyor

Bar and tube material supplied as bundles must be separated out in stages to allow automatic feed. In the device shown above, the stages are as follows: Lowering of filled trough to allow transfer to feed system, opening of hold-back arm, separation and feed of one piece of material and outward transfer of this via a roller conveyor. The alternative solution shown in Fig.b uses 2 rocker arms to achieve a gradual multi-stage transfer of bar material to a roller track. The downward-acting forces of the stored workpieces are lower in this case, which makes separation easier. The overall operation of the device requires synchronised interaction of the pneumatic drives.

Suitable components:

Standard cylinder DNC...
Proximity switch SM...
Rod eye SGS...
Swivel flange SNCS...
Clevis foot mounting LBG...
Pneumatic single pilot valve...
One-way flow control valve GR...
Mounting accessories
Fittings

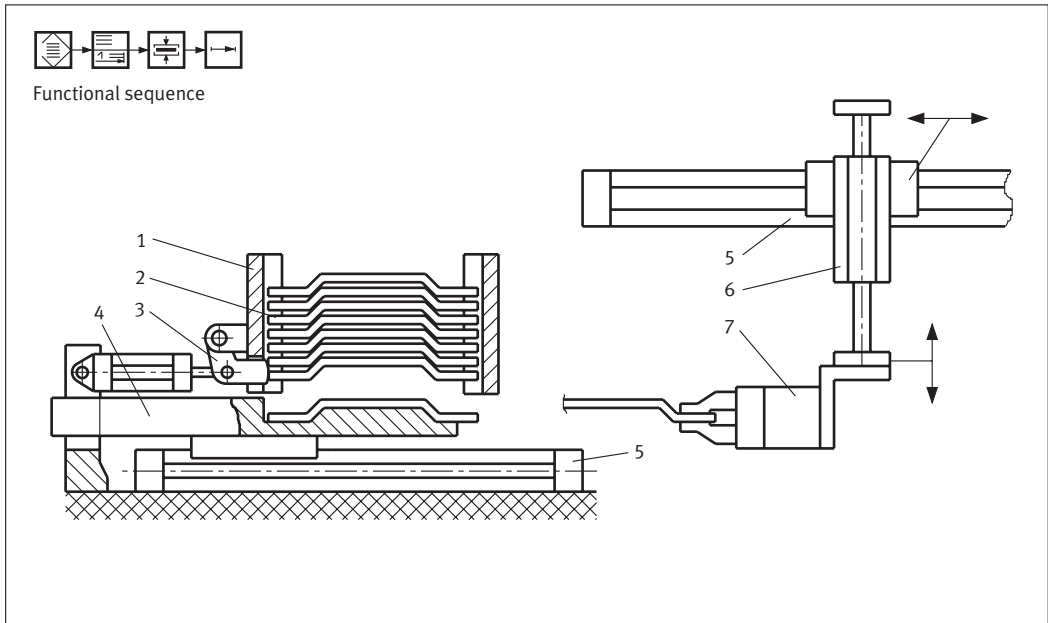

Feed system for undercut workpieces

- 1 Magazine
- 2 Workpiece (e.g. sheet-metal stamping)
- 3 Stop lever
- 4 Feed slide
- 5 Rodless linear drive
- 6 Lifting unit
- 7 Gripper

Undercut workpieces cannot simply be pushed from a stack or magazine with a slide, since their shape prevents this. In the solution shown above, the problem is solved by means of a stop lever. When the feed slide has advanced, the stop lever opens, allowing the magazine contents to move up and come into contact with the flat area of the slide. The stop lever now clamps the magazine stack again. Only the lowest workpiece in the stack is left loose and is not clamped. As the feed slide retracts, this workpiece is able to fall onto the shaped carrier of the slide. The slide now advances again and presents the workpiece to a handling device for feed to a machine.

Suitable components:

Rodless linear drive DGPL...
 Proximity switch SM...
 Pneumatic single pilot valve...
 One-way flow control valve GR...
 Parallel gripper HGP...
 Adapter kit HAPG...
 Compact cylinder AEVU...
 Swivel flange SUA...
 Rod eye SGS...
 Linear unit DPZJ...
 Mounting accessories
 Fittings

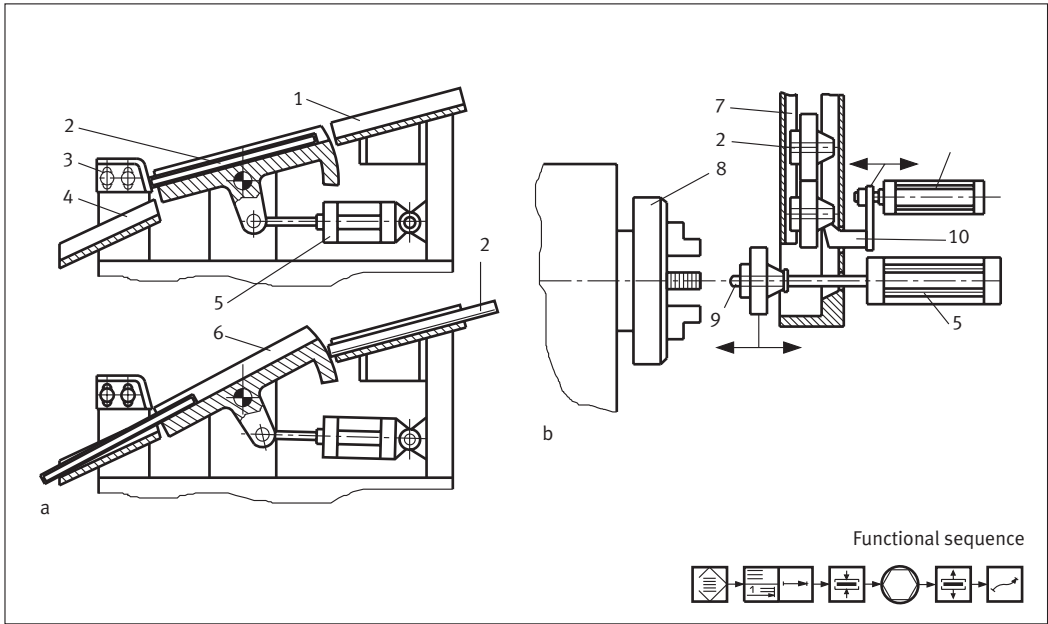

Feeding of workpieces

- a) Separation of flat workpieces
- b) Separation of round workpieces

- 1 Feed channel
- 2 Workpiece
- 3 Stop
- 4 Outlet channel
- 5 Pneumatic cylinder
- 6 Tilt plate
- 7 Stack magazine
- 8 Chuck
- 9 Carrier mandrel
- 10 Stop lever

In production operations, workpieces are generally fed one at a time in an action which can also be called “separation”. The illustration above shows two typical solutions. In the solution in Fig.a, the flat workpieces run up against a stop and remain in this position until the tilt plate moves upwards. The last workpiece on the plate, is now able to slide off this, whilst the flow of further workpieces is interrupted. A small angle of rotation is sufficient. The device in Fig.b shows how shouldered cylindrical workpieces can be separated and brought to a clamping point. Before workpieces are pushed out and input, the flow of further workpieces must be halted by the stop lever. Pneumatic components offer a very good means of creating a “separation” function.

Suitable components:

Compact cylinder AEVU...
 Swivel flange SUA...
 Rod eye SGS...
 Standard cylinder DNC...
 Foot mounting HNC...
 Proximity switch SM...
 Pneumatic single pilot valve...
 One-way flow control valve GR...
 Mounting accessories
 Fittings

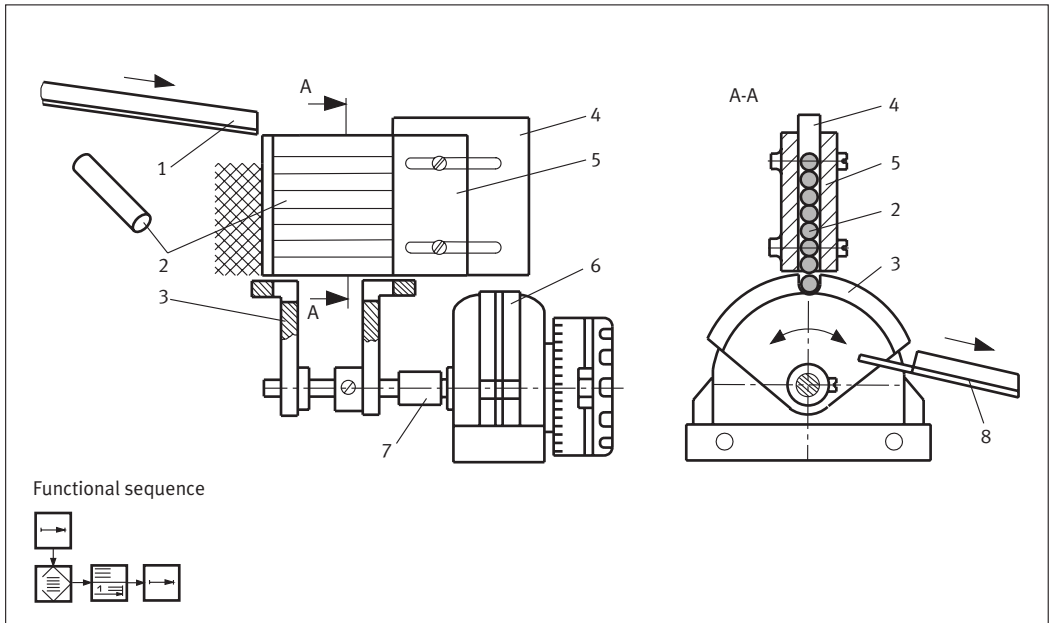
**Feed and buffer unit**

- 1 Feed channel
- 2 Workpiece
- 3 Swivel feed device
- 4 Longitudinal adjustment plate
- 5 Stack magazine
- 6 Semi-rotary drive
- 7 Coupling
- 8 Output channel

The unit shown above was developed for use with small workpieces which arrive longitudinally orientated from an upstream machine tool and need to be fed to a measuring device. It is able to store a small number of workpieces and thus decouples the devices to which it is connected. The magazine can also be refilled by hand without difficulty if necessary. As they emerge from the magazine, the workpieces require separation, which is achieved in this example by means of a rotary segment powered by a semi-rotary drive. The magazine can be set up for various workpiece lengths, as can the rotary segment. The output channel reaches to between the rotary segments, which means that the workpieces are virtually lifted by positive actuation. For workpieces of a different diameter, it is naturally necessary to fit a different magazine and rotary segment.

Suitable components:

Semi-rotary drive DSR...

Foot mounting HSR...

Proximity switch SM...

Pneumatic single pilot valve...or integrated into valve terminal CP..

Mounting accessories

Fittings

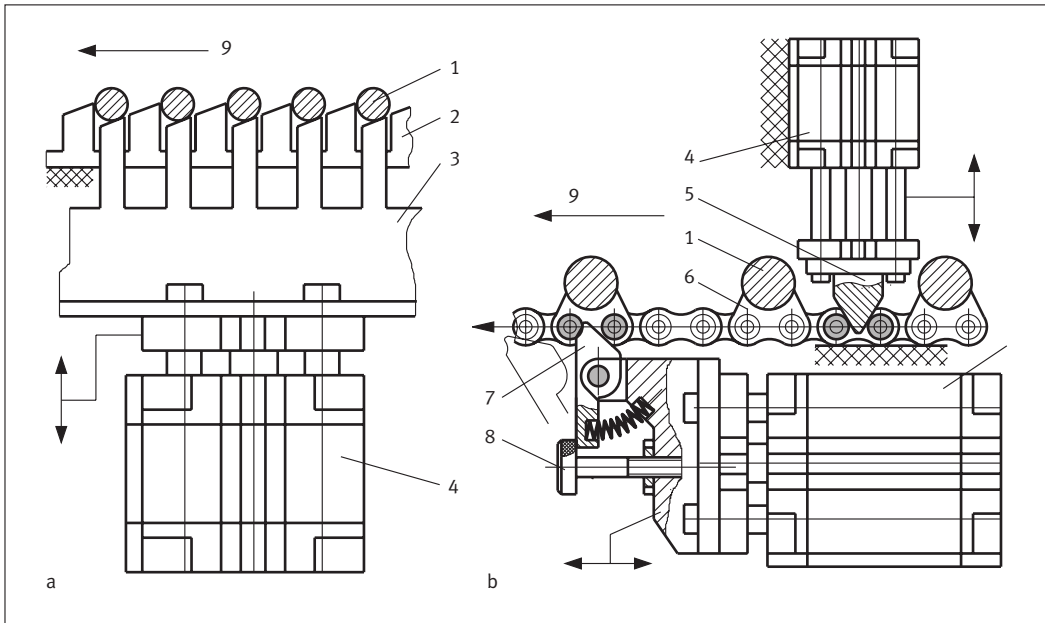

Forwarding device for bar workpieces

- a) Lifting rack system
b) Indexing chain system

- 1 Workpiece
- 2 Fixed rack
- 3 Lifting rack
- 4 Short stroke cylinder
- 5 Tapered locking pin
- 6 Special chain link for workpiece carrier
- 7 Movable detent
- 8 Adjusting screw (stop)
- 9 Direction of motion of workpieces

Whether as a magazine function or not, the indexed feed of workpieces is frequently required in assembly, testing, machining and other production operations. The lifting rack system shown in Fig.a is very simple. A short stroke cylinder is more than adequate as a drive. When the workpieces are lifted, they roll in the conveyor direction and each move up one position. It is also very simple to obtain an indexed motion with chains (Fig. b). The drive used in this case is a pneumatic cylinder. The chain is held in position during the return stroke of the detent, while the tapered locking pin maintains a precise workpiece position. The workpieces are located in trough-like carriers, which can be made from commercially-available chain links.

Suitable components:

Compact cylinder ADVUL...
Proximity switch SM...
Pneumatic single pilot valve...
One-way flow control valve GR...
Mounting accessories
Fittings

47
Glueing

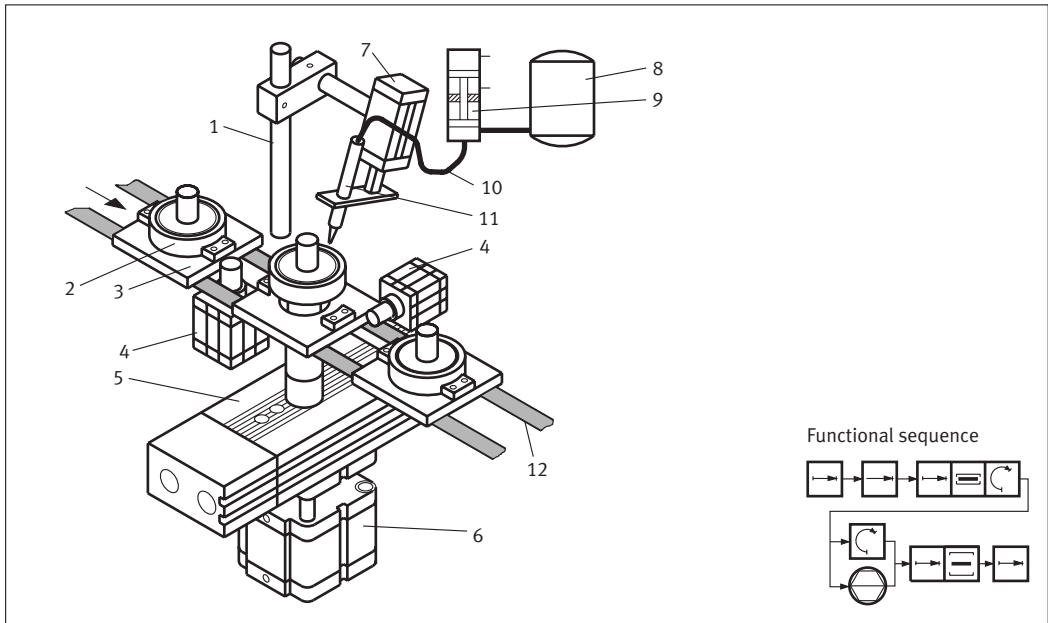

Adhesive applicator device

- 1 Stand
- 2 Workpiece assembly prior to adhesive application
- 3 Workpiece carrier
- 4 Stopper cylinder
- 5 Rotary unit
- 6 Lifting cylinder
- 7 Pneumatic cylinder
- 8 Adhesive reservoir
- 9 Dosing pump
- 10 Adhesive feed line
- 11 Applicator nozzle
- 12 Twin-belt transfer system

Glueing processes are becoming more and more widespread in industry, thanks to the development of high-performance application-specific adhesives. The illustration shows how adhesive is applied to a prepared joint. For this purpose, the workpiece assembly is lifted out of the workpiece carrier and rotated. The adhesive nozzle is brought to the workpiece assembly by a pneumatic cylinder. The workpiece carriers are normally also halted by means of pneumatic cylinders. The rotary unit must have a facility for fine adjustment of its speed of rotation. An electrically driven turntable can also be an advantage.

Suitable components:

- Compact cylinder ADVUL...
- Pneumatic single pilot valve...
- Proximity switch SM...
- Rotary drive DRQD...
- Flat cylinder DZF... or standard cylinder DSNUL... or SLT... or SLS...
- Fittings
- Mounting accessories
- Stopper cylinder STA...

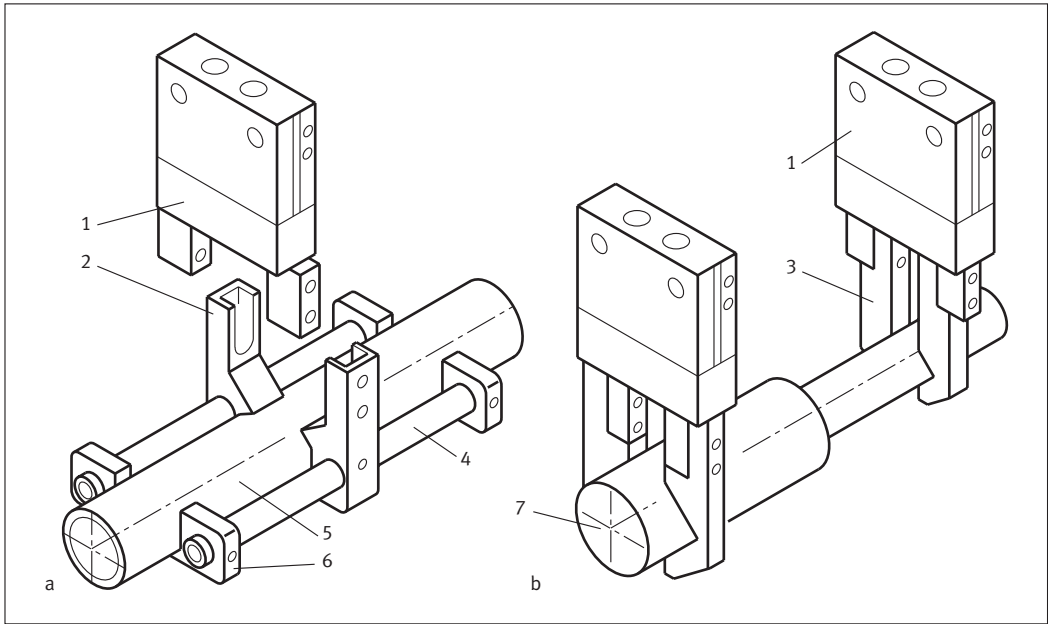

Application with parallel-jaw grippers

- a) Gripper-jaw design for long material
b) Parallel gripper configuration

- 1 Parallel gripper
2 Special gripper jaw
3 V-shaped gripper jaw
4 Retaining bar
5 Gripped object (tube)
6 Support jaw
7 Shouldered shaft

Pneumatically-driven grippers are robust and technically relatively simple; they are used in large numbers in all branches of industry. These are available as series-produced basic grippers, which then need to be adapted by users for a specific workpiece shape, which requires a certain amount of skill in order to achieve reliable handling. In the case of long shouldered workpieces, for example, it can be advantageous to use a parallel configuration of grippers with suitable v-jaws (for round-section workpieces), as shown in Fig. b. The other illustration shows special cantilever gripper jaws for the handling of tube material. These provide good protection against undesirable torque forces during handling operations and eliminate the possibility of incorrect workpiece orientation within the gripper. In all cases, however, it is important to observe the load graphs supplied with every gripper if the full quoted service life is to be achieved. If necessary, a larger gripper should be selected.

Suitable components:

Parallel gripper HGP...
Pneumatic single pilot valve...
Proximity switch SM...
Adapter kits HAPG...
Fittings
Mounting accessories

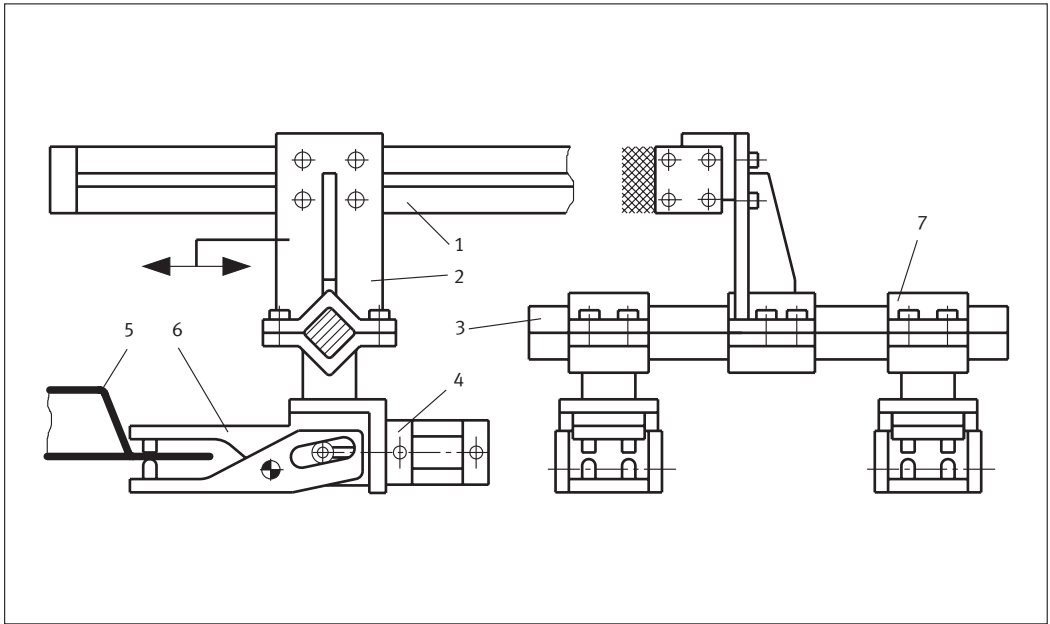

Gripper for removal of sheet-metal workpieces

- 1 Rodless linear drive
- 2 Support arm
- 3 Profile support
- 4 Pneumatic cylinder
- 5 Shaped sheet-metal workpiece
- 6 Gripper jaw
- 7 Clamp piece

When presses are linked to form production lines, this often requires handling devices to move sheet-metal workpieces from one press to another. Buffer stores are also sometimes used to bridge this distance. In the example above, drawn workpieces are picked up at their edges by tong-type grippers. The clamping force is generated pneumatically and amplified by means of an inclined slot. Grippers of this or a similar type are manipulated by industrial robots or, as in this example, driven by a linear axis. These linear axes are formed by single or, if required, twin rodless pneumatic cylinders, which are highly suitable for this purpose thanks to their ability to bridge large distances quickly. The example shown uses twin grippers, which can be positioned on the profile support as appropriate to the workpiece sizes in such a way that they grip the workpiece by its edges. The end of the clamp jaws are often equipped with carbide pressure pieces (individual pins or a pyramid-shaped ribbed surface) to ensure that even large workpieces can be held securely. Pressure pieces of this kind (sheet metal clamp pins) can be used only in cases where the drawing edges will be subsequently trimmed from the workpieces in question.

Suitable components:

Rodless linear unit DGPL...
 Pneumatic single pilot valve...
 Compact cylinder ADVU... or
 Standard cylinder DNG...

Proximity switch SM...
 Fittings
 Mounting accessories

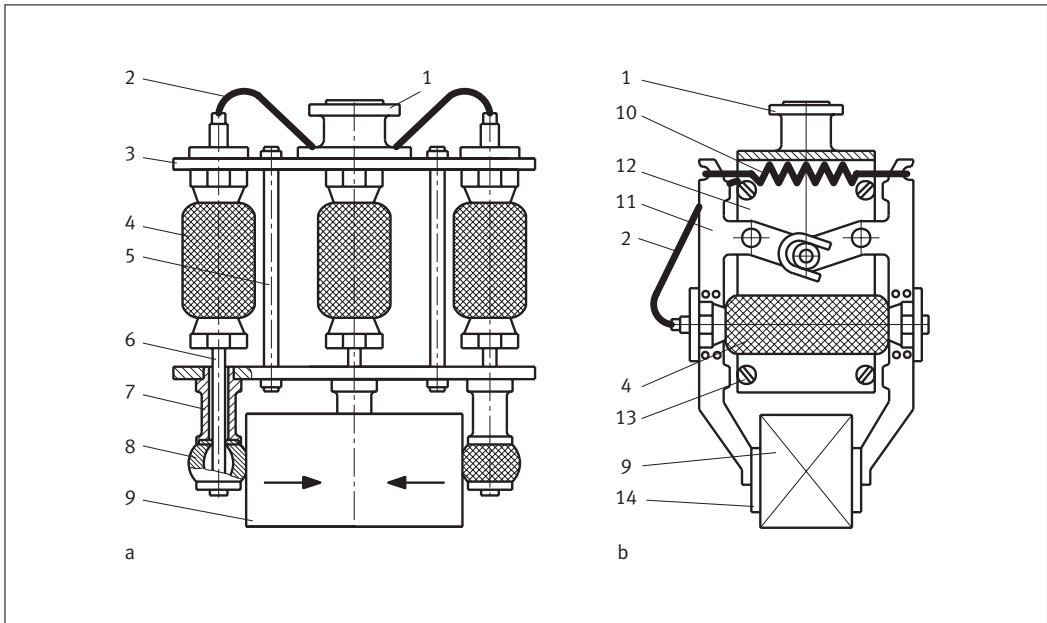

Special gripper with pneumatic drive

- a) Four-finger gripper
- b) Jaw-type gripper with Fluidic Muscle

- 1 Gripper flange
- 2 Compressed air supply line
- 3 Base plate
- 4 Fluidic Muscle
- 5 Spacer pin
- 6 Tie rod
- 7 Guide sleeve
- 8 Rubber body (thick-walled tubing)
- 9 Workpiece
- 10 Return spring
- 11 Gripper finger
- 12 Base plate
- 13 End stop pin
- 14 Gripper jaw

F_G Gripper force

Grippers for large or voluminous objects often require special solutions. It is by no means the case that the gripper stroke must also be large. New possibilities have been opened up by Fluidic Muscles. In example a, these muscles act via a tie rod to deform a rubber body, thus producing the desired holding effect. The gripper shown is of simple design, has in effect modular fingers and is lighter than a gripper with a pneumatic or hydraulic piston system. The gripper object is held gently, thus preventing damage to objects with sensitive surfaces such as paint, polish or screen printing.

In the case of the gripper shown in Fig. b, the tensile force of the muscle when pressurised is converted into a gripper finger motion. The Fluidic Muscle has a service life of at least 10 million load cycles. Further advantages: Lower energy consumption than comparable cylinders, unaffected by dirt, water, dust and sand.

Suitable components:

- Fluidic Muscle MAS...
- Pneumatic single pilot valve....
- Fittings
- Mounting accessories

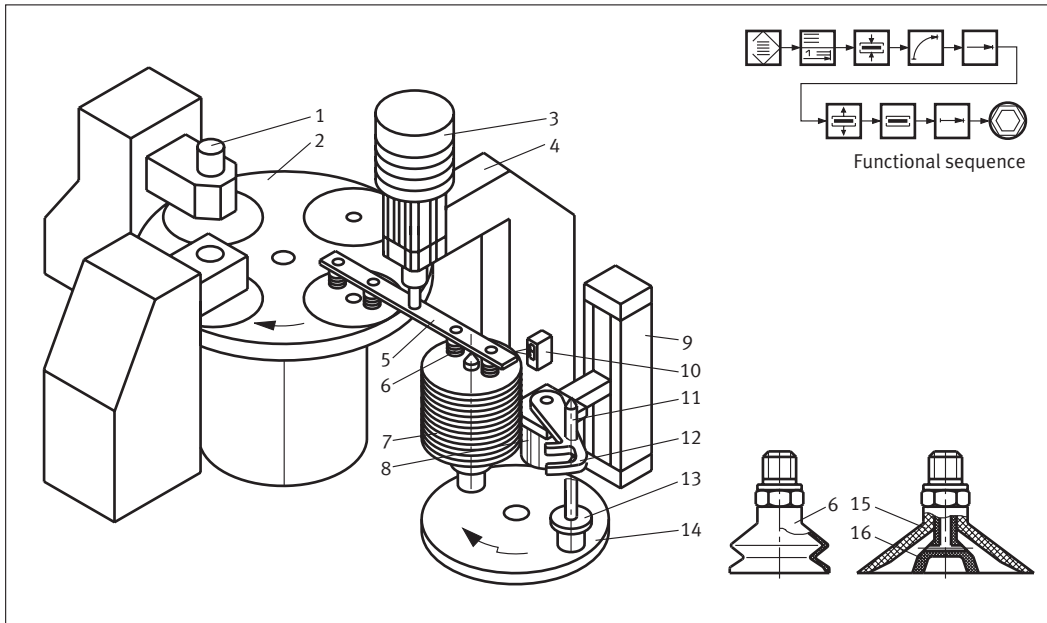

Feed system for thin discs

- 1 Processing
- 2 Rotary indexing table
- 3 Swivel/linear unit
- 4 Frame
- 5 Swivel arm
- 6 Bellows suction cup
- 7 Stacks of discs
- 8 Swivel unit
- 9 Positioning axis
- 10 Proximity sensor
- 11 Magazine rod
- 12 Yoke lifting arm
- 13 Support plate
- 14 Magazine plate
- 15 Suction cup
- 16 Core piece to isolate vacuum from hole in workpiece centre

This example shows how discs can be fed from a magazine to a machine tool. The workpieces are held in a magazine in such a way that a lifting arm can travel underneath the stack. The arm is then lifted in steps, triggered by a sensor signal. A double swivel arm is used to transfer workpieces to the machine tool, allowing setdown and lifting at the same time. A disc suction cup is used in cases where the workpieces have no centre hole and are fixed in place in the machine by their edges. It is also possible to use two bellows suction cups, and furthermore there are disc suction cups which can be converted into ring-shaped cups (see bottom right of illustration).

Suitable components:

- Swivel/linear unit DSL...
- Suction cup VAS... or bellows suction cup VASB...
- Electromechanical axis DGEL... -SP...
- Stepper motor VRDM... and positioning controller EPS...
- Proximity switch SM...
- Swivel unit DSM...
- Pneumatic single pilot valve...
- Diffuse sensor SOEG...
- Mounting accessories
- Fittings

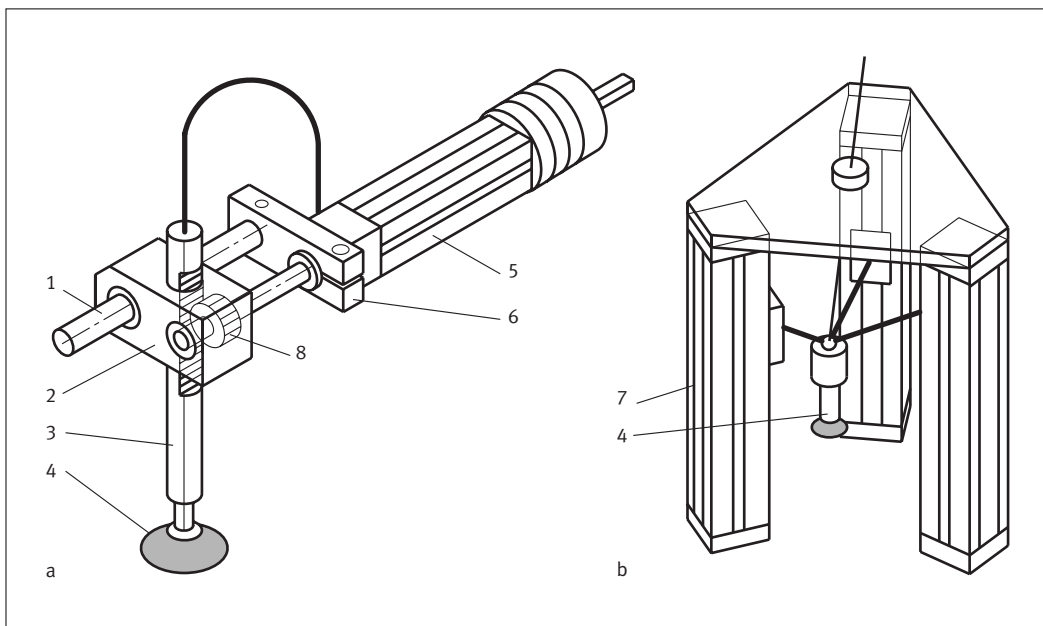

Pick-and-place units

- a) Twin-axis pick-and-place unit
- b) Three-axis handling device with a hexapod design

- 1 Guide rod
- 2 Guide block
- 3 Hollow rod with gear rack
- 4 Disc suction cup
- 5 Swivel/linear unit
- 6 Clamp piece
- 7 Rodless linear unit or positioning axis

A variety of pick-and-place devices are available for the handling of small work-pieces in assembly, testing and packaging processes. These devices are generally able to approach only a limited number of positions in two dimensions, or more rarely three dimensions. The solution variant shown on the left uses a swivel/linear unit; a rotary motion is converted into a second linear motion by means of a rack-and-pinion gear mechanism, which allows the actuator to produce a cyclic rectangular motion. The assembly is relatively simple and can be created from just a few individual components. In the case shown on the right, 3 linear units have been linked via rods to a gripper unit to produce a “half” hexapod. Configurations of this kind have certain advantages and have become popular in recent years. If pneumatic end-position units are used, the grippers are naturally able to approach only $2_n = 8$ positions. With programmable electrical or servo-pneumatic linear axes, the number of possible positions is unlimited. Pneumatic axes, however, allow very fast motion cycles to be achieved.

Suitable components:

Swivel/linear unit DSL...
 Fittings
 Pneumatic single pilot valve... accessories
 Proximity switch SM...
 Suction cup VAS... or gripper HG...

Rodless linear unit DGP...
 or Positioning axis DGE...
 with multi-axis positioning Mounting controller MPS...

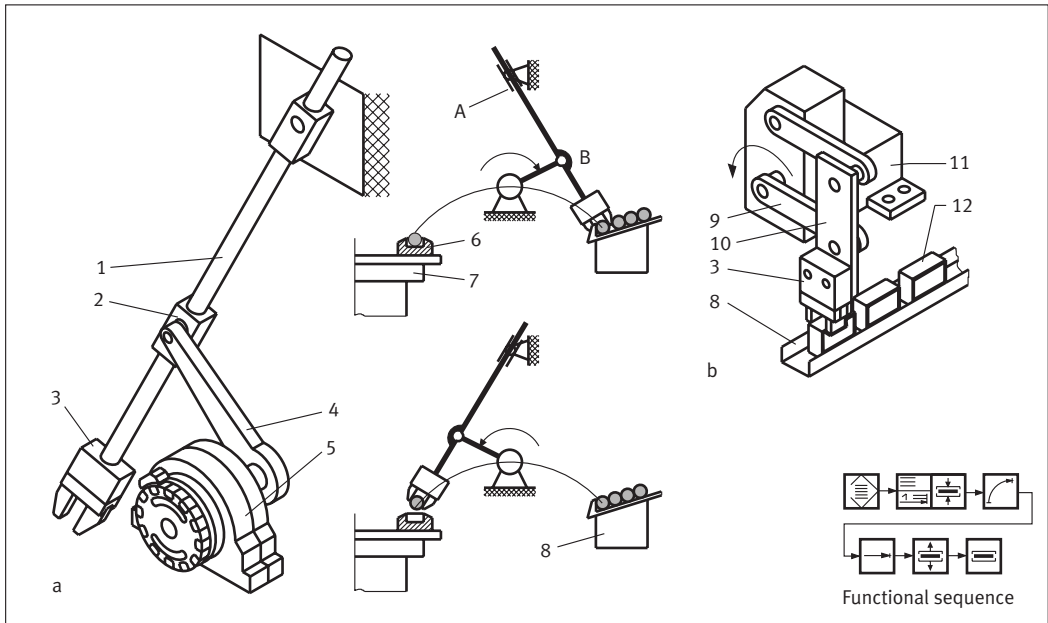

Pick-and-place devices

- a) Swivel arm pick-and-place device
- b) Pick-and-place device with coupling gear unit

- 1 Guide rod
- 2 Rotary joint
- 3 Gripper
- 4 Swivel arm
- 5 Semi-rotary drive
- 6 Workpiece carrier
- 7 Rotary indexing table machine
- 8 Feed magazine
- 9 Coupling gear unit
- 10 Gripper adapter plate
- 11 Housing with rotary unit
- 12 Workpiece

Many simple feed and assembly processes can be reduced to two-dimensional motion cycles, in which the only requirement is for end positions to be approached accurately. Pick-and-place units are more than adequate for this and can be assembled on the basis of pneumatic drives. The examples shown above have a main swivel motion. Workpieces are picked from a magazine and placed, for example, at the clamping point of a rotary indexing table machine. In the solution shown in Fig. a, the pick and place operations are never precisely vertical, due to the position of the pivot point of the main rod, unless points A and B lie on precisely the same vertical line. In the solution in Fig. b, the motion forms an arc. In this case, both the pick and place operations are carried out vertically from above. In both cases, pneumatic rotary units are used.

Suitable components:

- Semi-rotary drive DSR...
- Gripper HG... or suction cup VAS...
- Proximity switch SM...
- Pneumatic single pilot valve....
- Fittings
- Mounting accessories

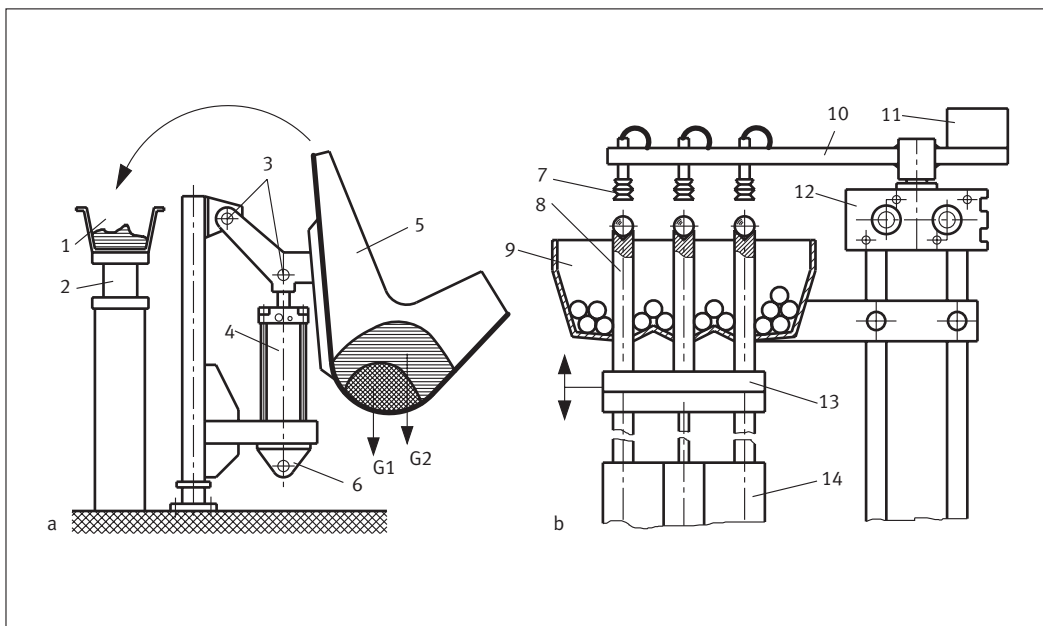

Feed of materials and workpieces stored in hoppers

- a) Bulk-material hopper
b) Sorting and feeding of balls

- 1 Chute
- 2 Linear vibrator system
- 3 Shear bolt sensor
- 4 Pneumatic cylinder
- 5 Swivelling hopper
- 6 Swivel flange
- 7 Bellows suction cup
- 8 Lifting ram
- 9 Hopper
- 10 Swivel arm
- 11 Counterweight
- 12 Rotary unit
- 13 Lifting plate
- 14 Vertical lifting unit

- G Weight force of bulk material

Hoppers are used to store workpieces in random orientation or shapeless bulk materials. In Fig.a of the example, bulk material is output via a vibrator chute. The two articulated joints of the swivel mechanism are fitted with shear bolt sensors which are used to calculate the weight of material in the bunker. This allows the feed of various batches of pre-weighted materials. Fig.b shows the sorting and feeding of balls. These can always be brought into the desired state by simple means, since they are symmetrical on all axes. The device presents the extracted balls immediately to a suction cup gripper which swivels the balls to an assembly or packing station. The tops of the lifting rams are equipped with a tapered depression. This design allows a simple and inexpensive solution to be achieved.

Suitable components:

Standard cylinder DNC...
Mounting accessories Swivel flange SSNG...
Pneumatic tubing Proximity switch SM...
Fittings Pneumatic single pilot valve VL...
Rotary drive DRQD...
Bellows suction cup VASB...
Vacuum efficiency valve ISV...
Vacuum generator VAD...
Drive unit DFM...

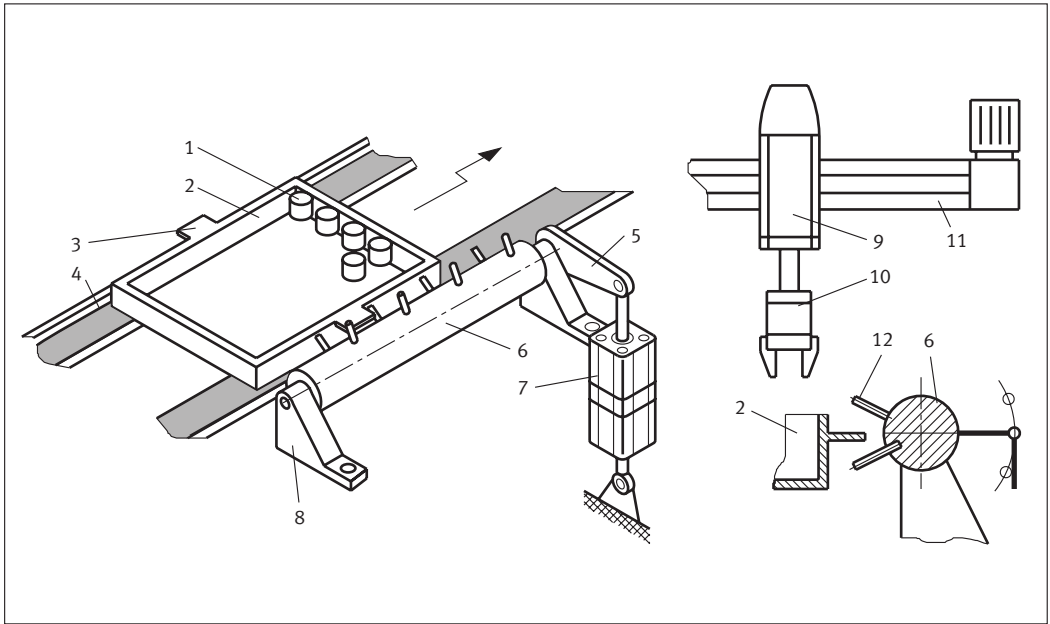

Controller drum for indexing workpiece carrier magazines

- 1 Workpiece
- 2 Workpiece carrier magazine
- 3 Stop lug
- 4 Conveyor belt
- 5 Driver arm
- 6 Controller drum
- 7 Three-position cylinder
- 8 Clevis foot mounting
- 9 Lifting unit
- 10 Gripper
- 11 Positioning axis
- 12 Pin cam

In order to break up a group of workpieces (unloading) or create a group (magazing), we often require a handling unit which can be positioned on two axes. The cost of the system can be reduced if the positions of one axis are controlled by a drum with cam pins. These cams are spaced at intervals equal to the spacing of the rows of workpieces in the magazine. As the drum turns back and forth, the magazine moves forward by one product row. A third drum position, the centre position, is required in order to allow the magazine to pass through the station without stopping. If the workpieces are to be picked up not in rows but individually, then this will of course require a positioning axis for the handling unit. It would also be possible, instead of the cam drum, to use a stop system based on slim flat cylinders. For large distances, stopper cylinders can also be used.

Suitable components:

Multi-position cylinder ADVUP...

Mounting kit DPVU...

Parallel gripper HGP...

Proximity switch SM...

Pneumatic single pilot valve...

Linear module HMP...

Electrical positioning axis DGE...and single-axis positioning controller EPS...

Mounting accessories

Fittings

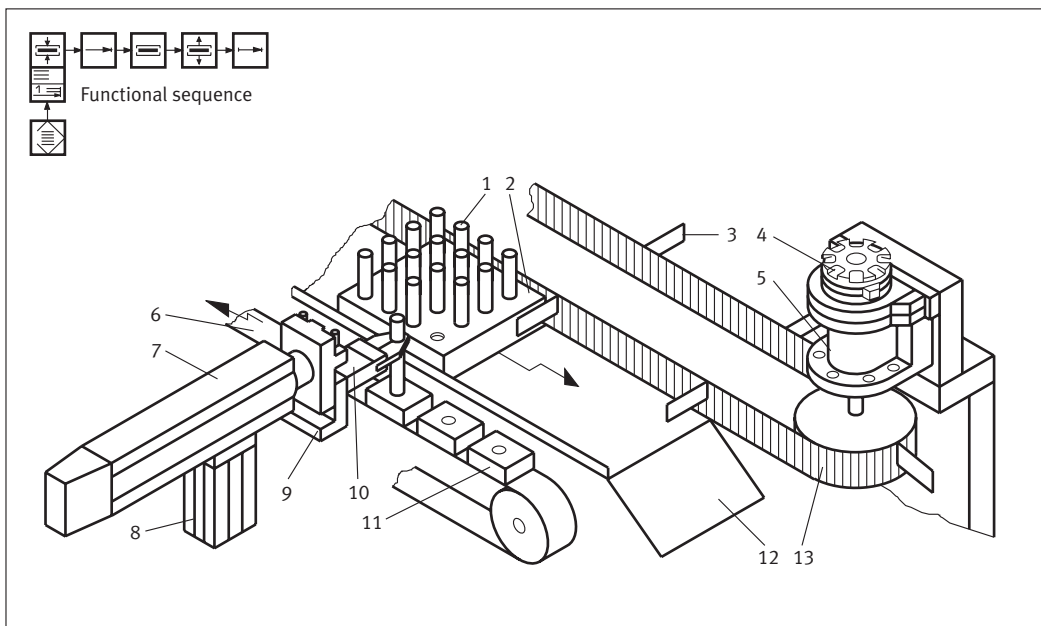

Fitting basic workpieces with additional components

- 1 Joining component
- 2 Workpiece carrier magazine
- 3 Driver
- 4 Semi-rotary drive
- 5 Freewheel unit
- 6 Transfer system
- 7 Linear unit with intermediate positions
- 8 Stand
- 9 Mini slide
- 10 Gripper
- 11 Basic workpiece or workpiece carrier
- 12 Empty magazine output
- 13 Chain conveyor

This example shows a typical handling sequence of the kind frequently encountered in assembly work – the insertion of pins into holes. The object containing the holes may be a workpiece carrier or a basic workpiece. To allow the pins to be handled row by row, the horizontal linear unit has pneumatically-controlled intermediate positions. The pin magazine is indexed one row at a time by a fan-type conveyor, while forward advance is provided by a rotary unit fitted with a freewheel unit. Although the entire procedure consists of several sequences, it can be produced in very reliable form by using simple pneumatic components. The positioning method used, against stops, also gives good repetition accuracy.

Suitable components:

- Mini slide unit SLT...
- Linear module HMP...
- Adapter kit HAPG...
- Parallel gripper HGP...
- Semi-rotary drive DSR...
- Proximity switch SM...
- Pneumatic single pilot valve VL... but generally a valve terminal CP...
- Foot mounting HSR...
- Freewheel FLSR...
- Mounting accessories
- Fittings

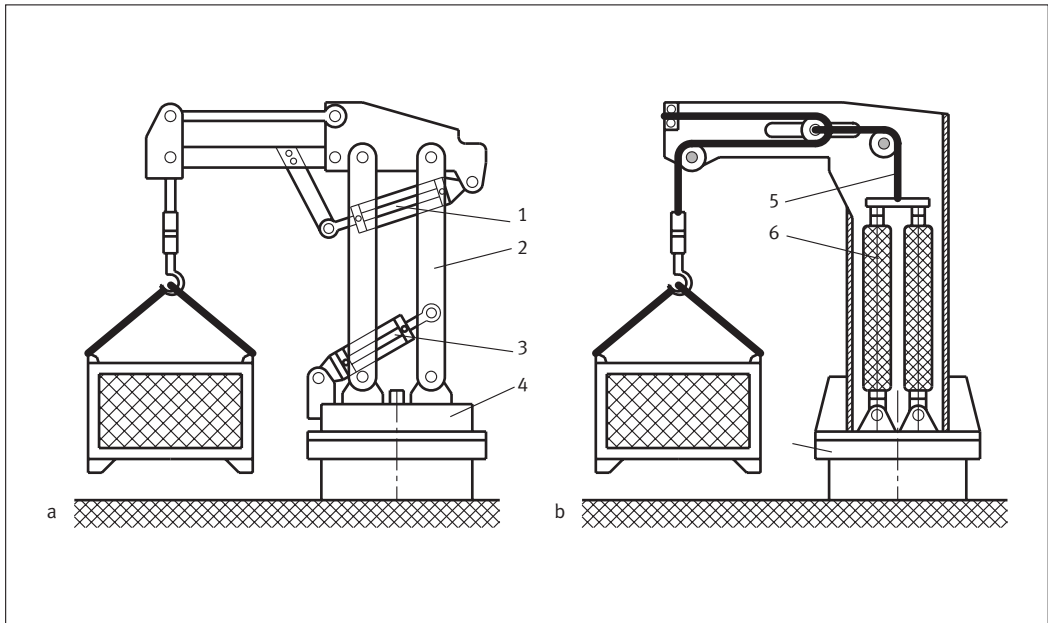

Mechanised lifting units

- a) Articulated arm system
- b) Using Fluidic Muscles to generate lifting force

- 1 Pneumatic cylinder to drive lower arm
- 2 Coupling gear unit
- 3 Upper arm drive
- 4 360° turntable
- 5 Cable, chain, belt or strap
- 6 Fluidic Muscle

There is a need in every workshop and factory to lift workpieces, pallets, materials and equipment. Many devices are available commercially for this purpose. For special cases, however, customer-built lifting devices are produced. For example, pneumatic cylinders can be connected to parallelogram arms in such a way as to create crane-like devices. This can be achieved very easily by using Fluidic Muscles. In the example shown on the right above, the load carrier is connected to the device via a loose roller. This makes the effective stroke twice as large as the stroke produced by the Fluidic Muscle as this contracts by approx. 20% of its initial length. If force generators are arranged in parallel, then, as we would expect, the lifting force is also doubled. Both the devices shown above are mounted on turntables, thus allowing 360° operation. In terms of vertical stroke, this type of lifting unit is not able to compete with other types of device. For many applications, however, a small stroke is ample. Both types of device can also be designed for ceiling installation.

Suitable components:

Standard cylinder DNG... or DNC...
 Rod eye SGS...
 Clevis foot mounting LSNG...
 Pneumatic single pilot valve...
 Proximity switch SM...
 Fluidic Muscle MAS...
 Mounting accessories, fittings

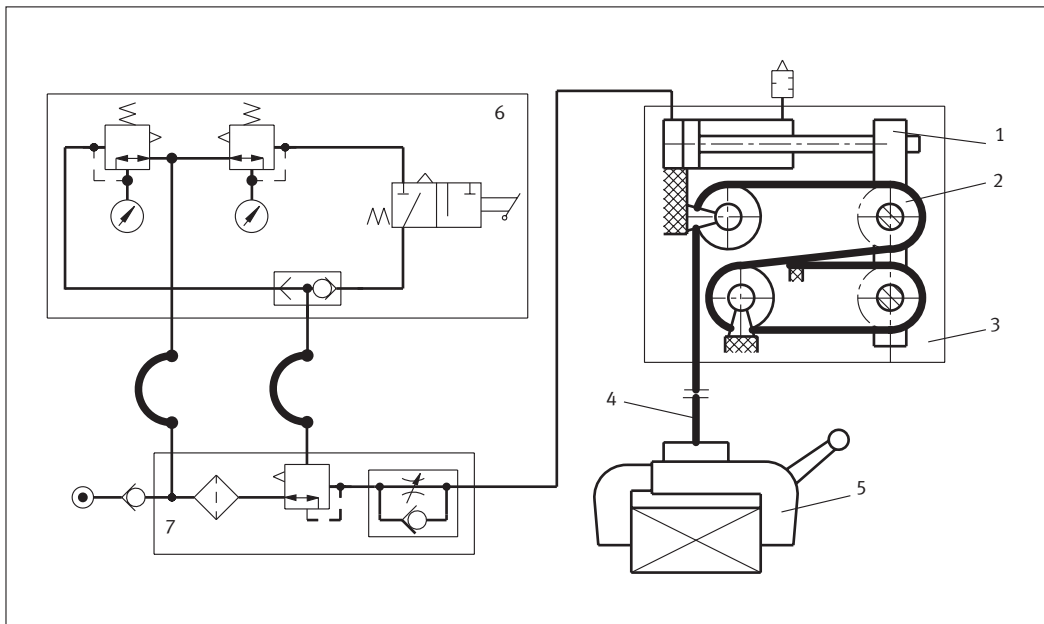

Balancer load lifting device

- 1 Roller arm
- 2 Roller
- 3 Lifting unit
- 4 Cable, chain, belt or strap
- 5 Mechanically or pneumatically-driven gripper device
- 6 Pneumatic piloting
- 7 Auxiliary air regulator

Balancers are hand-guided lifting devices which can be used to hold suspended loads against the force of gravity. This avoids the need for severe physical effort. The motions of balancers are not pre-programmed. The required compensating force is generated pneumatically, usually with the aid of a cylinder. In future, Fluidic Muscle will also be used, giving lower weight and more dynamic operation. The balancer circuit in the illustration is designed for a single load. There are also circuits that allow a selection of several preset loads. In order to make it possible to handle any desired weights (within the safe working limit) in any desired order, a weighing device must be installed between the load carrier and the lifting device. The resulting weight value is then used to control the pneumatic “counter-holding force”. Balancers have become very common in recent years.

Suitable components:

- Standard cylinder DNG... or DNC...
- Pneumatic single pilot valve...
- Proximity switch SM...
- One-way flow control valve GRLA...
- Pressure regulator LRMA...
- Non-return valve H...
- OR gate OS...
- Mounting accessories
- Fittings

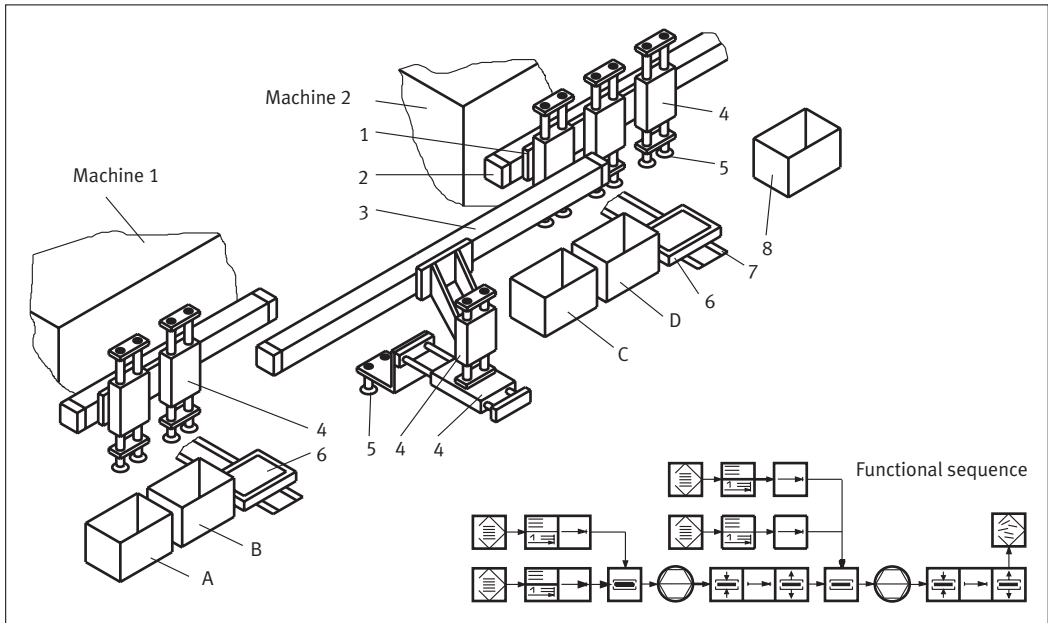

Linking two assembly machines

- 1 Slide
- 2 Rodless linear unit
- 3 Long-stroke cylinder as linking device
- 4 Lifting slide
- 5 Suction cup
- 6 Tool
- 7 Insertion unit
- 8 Finished workpiece magazine

A, B, C, D
Workpieces for assembly

In machine 1, the basic component A and the joining part B are laid in succession into the tool suggested in the illustration. The tool travels into the machine and the assembly operation takes place. The actual assembly unit is not shown. The partially finished assembly is then picked up by suction cups and fed into the tool of machine 2, where the joining parts C and D are fed in one after the other. The assembly sequence then continues. As the joining parts are set up, the finished assembly is at the same time picked up by suction cups, lifted out of the machine and set down in the finished-workpiece magazine. All 3 lifting units of machine 2 are installed on a slide at the same intervals as the magazine operating positions. The linear feed units approach 3 positions at a time. The transfer unit for machine 2 travels only between its end positions. A central parking position for this slide would be advantageous if it were ever necessary to feed the machines by hand.

Suitable components:

- | | |
|-----------------------------|---------------------------------|
| Rodless linear unit DGPL... | Vacuum efficiency valve ISV... |
| Proximity switch SM... | Mounting accessories |
| Linear unit SLE... | Fittings |
| Standard cylinder DSN... | Pneumatic single pilot valve... |
| Suction cup VAS... | |
| Vacuum generator VAV... | |

59 a
Linking

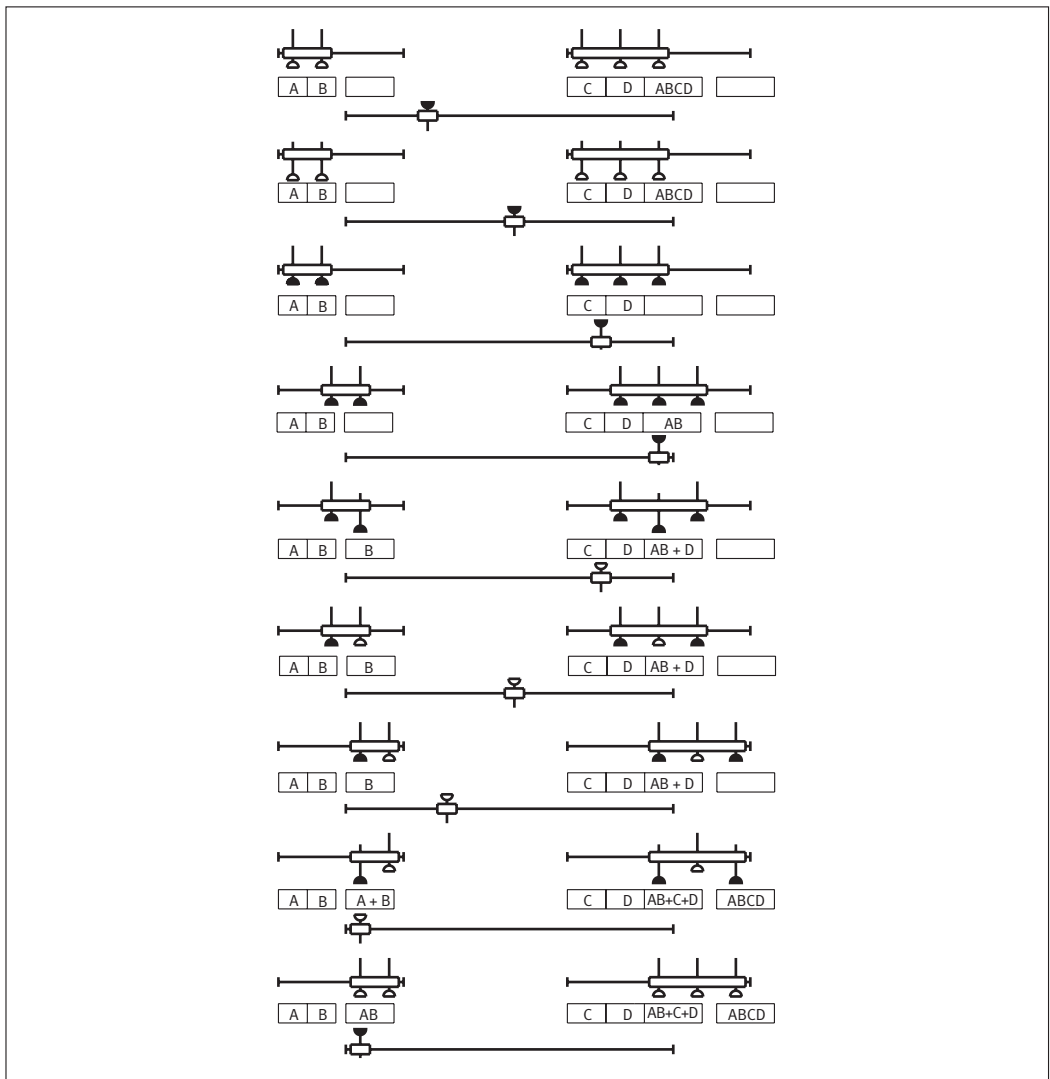

The illustration shows the motion sequence of the handling units in example 84. Suction cups are shown as solid black if they currently hold a workpiece. The fully finished assembly is designated ABCD, while sub-assemblies are designated AB.

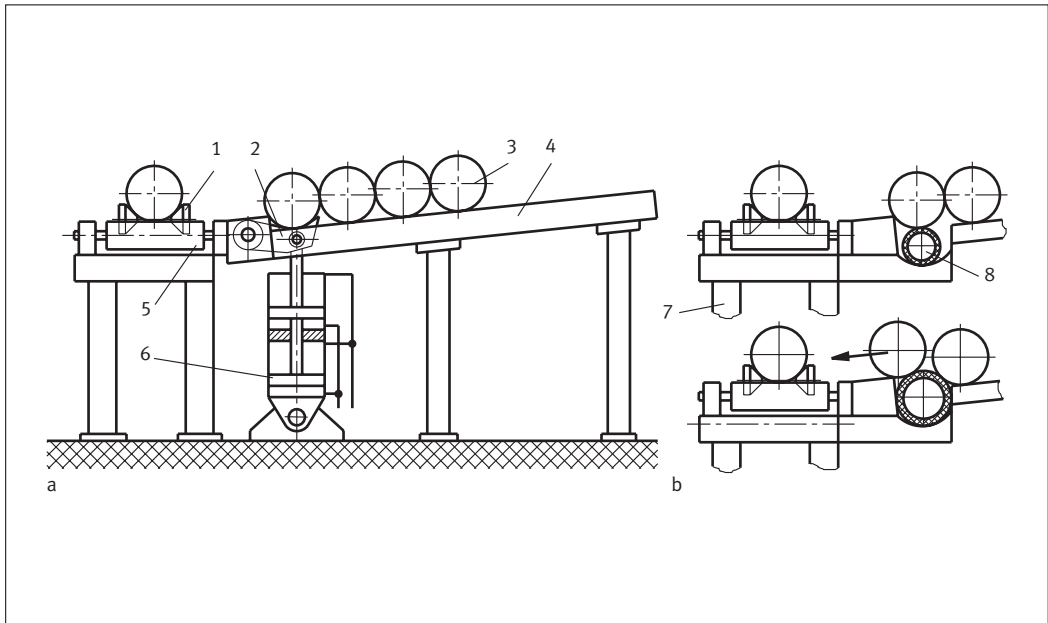

Loading table for round-section material

- a) Loading using a loading-lever distributor
 b) Loading using Fluidic Muscle

- 1 Lowerable lateral guide roller
 2 Loading lever
 3 Round-section material
 4 Roller conveyor
 5 Support roller
 6 Pneumatic cylinder
 7 Frame
 8 Fluidic Muscle

Loading tables must be of robust construction to ensure that they can be used with heavy workpieces. Round-section material rolls as far as the loading lever (distributor) which lifts the material, thus allowing it to pass onto the roller conveyor. If a pneumatic cylinder is not able to supply sufficient power for this, a toggle mechanism can be interposed. The loading lever is adjustable for different bar-material diameters. This is the only adjustment required. The guide rollers of the roller conveyor rise automatically when the bar material arrives at the support rollers. The guide rollers halt the workpiece in the centre of the roller conveyor and provide lateral guidance. As the loading lever lowers, the material flow moves up and the loading procedure is repeated after the connected machine tool has used up a bar of material. It would also be conceivable to replace the loading lever with a Fluidic Muscle to act as an air cushion, as shown in Fig. b. This muscle would then be laid in a fixed trough to cover the entire length of the bar material.

Suitable components:

Twin cylinder ADVUT... or standard cylinder DNG... or DNC...
 Fluidic Muscle MAS...
 Pneumatic single pilot valve...
 Swivel flange SUA...
 Rod clevis SG...
 Proximity switch SM...
 Mounting accessories, fittings

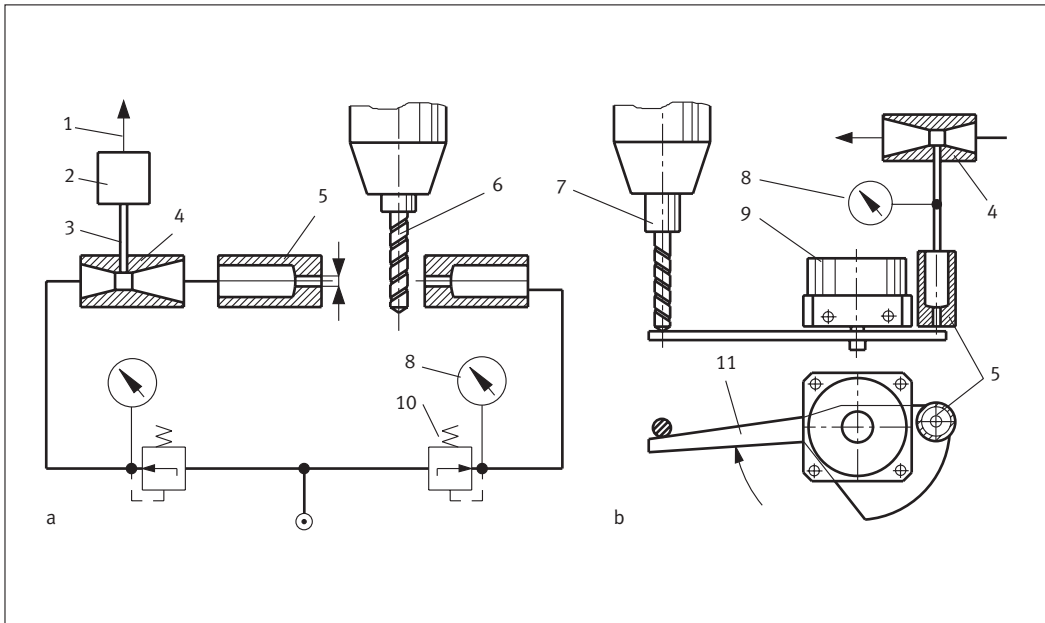

Pneumatic drill bit breakage monitoring

- a) Contactless monitoring with air jet
- b) Monitoring by feeler lever

- 1 Electrical signal
- 2 Vacuum switch
- 3 Vacuum duct
- 4 Venturi nozzle
- 5 Nozzle
- 6 Monitored object
- 7 Chuck
- 8 Vacuum gauge
- 9 Rotary unit
- 10 Pressure regulator
- 11 Feeler lever

Tool breakage monitoring is a vital part of automated production. Many devices have been created for this purpose. One contactless variant (Fig. a) uses an air barrier to monitor the presence of a drill bit. If the drill breaks off, it ceases to act as a rebound surface, and this change can be detected as a change of pressure. The nozzle bore has a diameter of 1 mm and the calibrated length is approx. 4 mm. In the solution shown in Fig. b, on the other hand, the drill tip is sensed by a feeler lever. If the drill bit breaks, the lever is able to swing right round, thus opening a nozzle hole. Once again, the pressure change in the system indicates tool breakage. An advantage is that the detection position can be adjusted to a tenth of a millimetre. Before measurements are taken, however, the drill bit should be cleaned by means of a jet of air or coolant. The increase travel of the lever in the case of tool breakage can also be detected by means of inductive sensors on the swivel module.

Suitable components:

Gap sensor
 Swivel module DSM...
 Vacuum generator VAS...
 Mounting kit WSM...
 Proximity switch SM...
 Pressure regulator LR...
 Vacuum switch VADM...
 Mounting accessories, Fittings

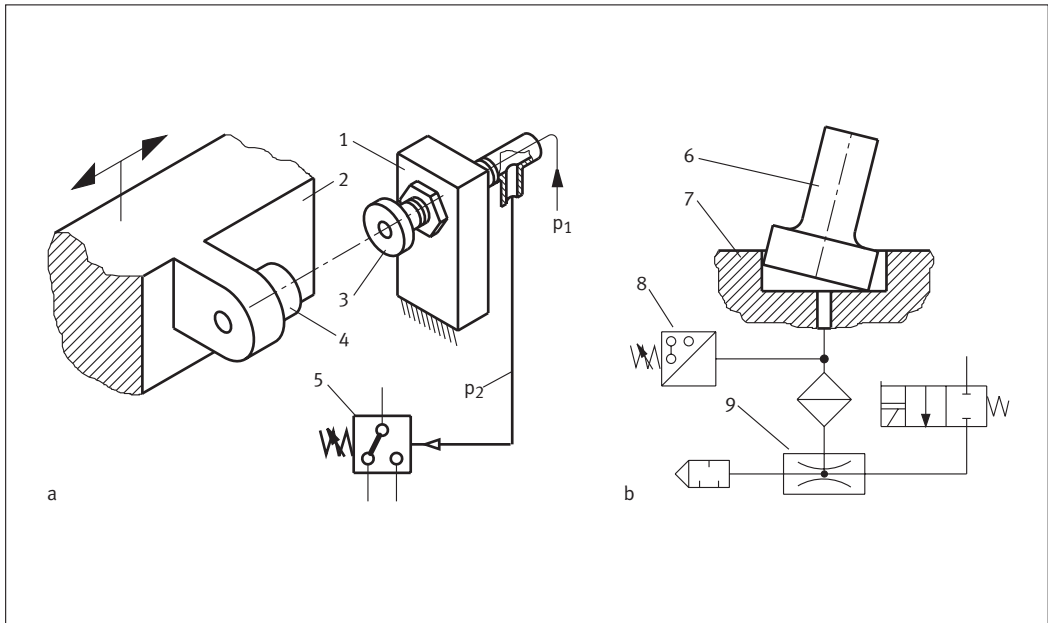

Checking and monitoring with air

- a) End-position monitoring
- b) Checking workpiece position

- 1 Stop block
- 2 Slide or moving machine part
- 3 Stop bolt
- 4 Stop buffer, or if appropriate shock absorber
- 5 Pressure switch
- 6 Workpiece
- 7 Vacuum clamp plate
- 8 Vacuum switch
- 9 Venturi nozzle

- P_1 Supply pressure
- P_2 Back pressure

Users who have selected pneumatic energy to carry out all the operations within a process will often wish to deploy air for monitoring purposes as well. This is entirely feasible. One simple method, for example, is to use a longitudinally drilled stop bolt, which becomes a jet nozzle. When the slide impacts against this, a pressure change results which is detected and evaluated by the pressure switch. The stop bolt thus becomes a multi-function component, providing the functions of position adjustment and a presence sensor. In the example in Fig. b, the workpieces are held at a clamping position by suction. If the clamping point is unoccupied or if its status is unclear due to swarf or tilted workpieces, the normal vacuum cannot be created; this fact can be detected and evaluated. If the vacuum provided by the vacuum generator is not sufficient to hold the workpiece securely in the workpiece carrier, a high-performance vacuum pump must be used.

Suitable components:

Vacuum generator VA...
 Pressure switch PEV...
 2/2-way valve MEBH...
 Vacuum switch VADM...
 Mounting accessories
 Fittings

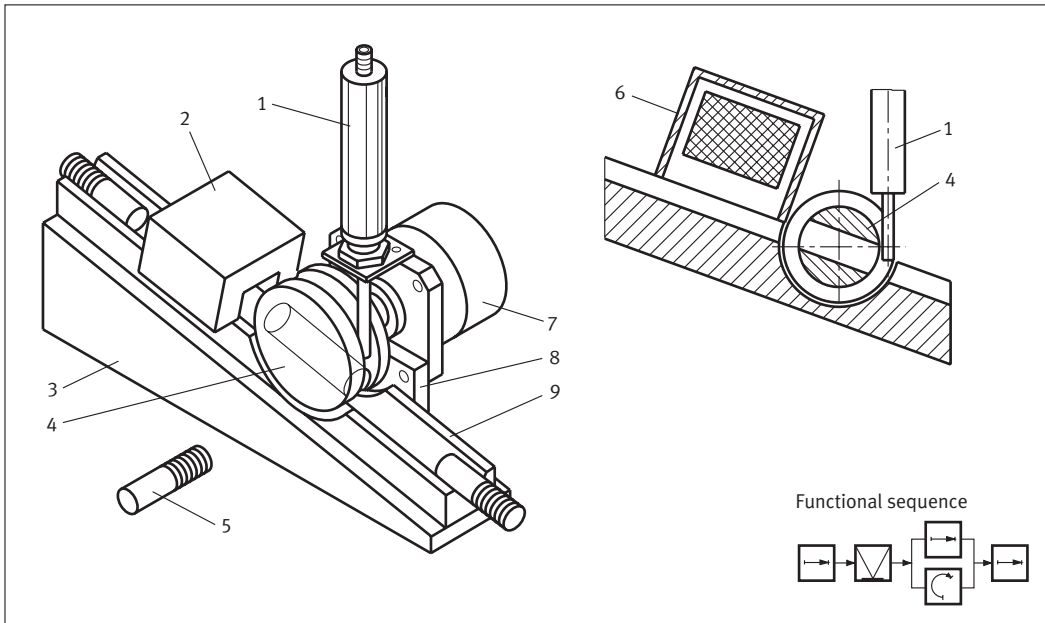

Orientation of workpieces with distinguishing features on one side

- 1 Stopper cylinder
- 2 Electromagnetic field sensor
- 3 Base
- 4 Orientation rotor
- 5 Workpiece
- 6 Shield
- 7 Rotary unit
- 8 Mounting flange
- 9 Chute

It is fairly easy with vibrators or other hopper feed devices to achieve a pre-orientation of workpieces in accordance with their longitudinal axes. If, however, there are differences between the ends of these workpieces (small shoulders, threads, flats, holes), it is necessary to provide a second final orientation operation. The illustration above shows a device for this purpose, which provides correct side-to-side orientation. The workpiece shown is just an example and could be any one of many similar round or v-shaped workpieces with a pronounced longitudinal axis. The different ends of the workpiece are detected as this passes through a high-frequency magnetic field. The sensor divides the workpiece into four sections for measurement purposes and compares the data from these in order to detect asymmetries. Control signals are then derived from this. It is, however, necessary to feed workpieces singly and separated by a gap. If these are correctly oriented, they pass through the rotary unit unimpeded. Incorrectly oriented workpieces are halted by the stop pin and turned through 180° by the orientation rotor. The workpieces are then released and travel onwards, while the orientation rotor is reset for the next orientation operation. In applications with small workpieces and high throughput rates, it is also possible to use the Festo Checkbox, which allows the optical detection of workpiece features.

Suitable components:

Swivel module DSM...
Standard cylinder ESN.
Flange mounting FBN...

Proximity sensor SM...
Mounting accessories
Fittings

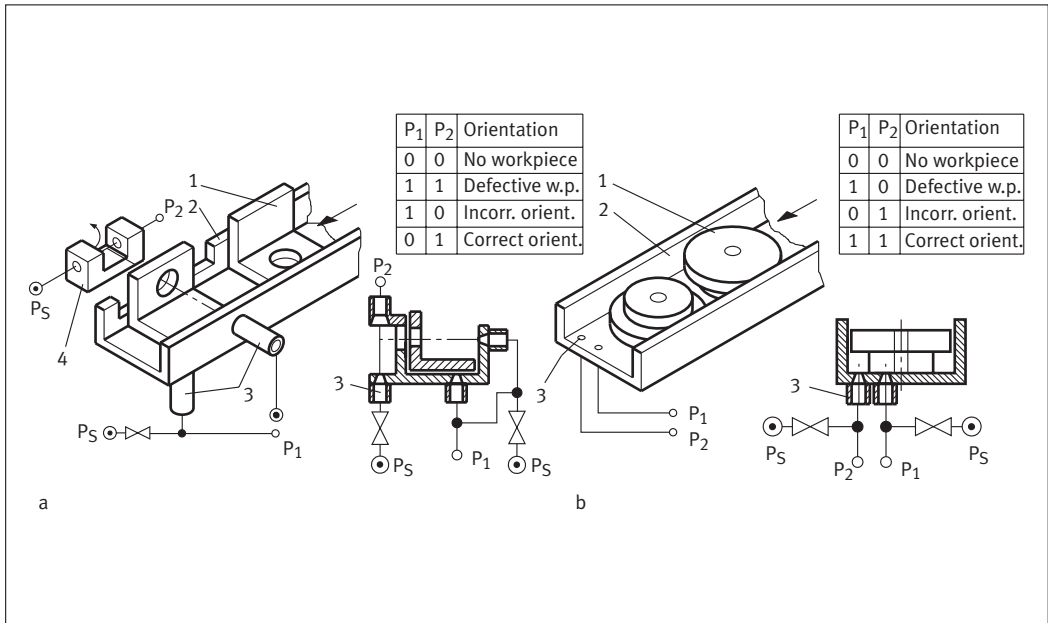

Detection of workpiece orientation

- a) Interference barrier sensor
b) Twin nozzle system

- 1 Workpiece
2 Feed chute for workpiece flow with gaps
3 Compressed air nozzle
4 Gap sensor P₁ and P₂
Measured signals

P_p Pilot pressure

In applications where it is desired to totally eliminate any miss-alignment of simple pre-oriented round or v-shaped workpieces, it is first necessary to determine the current orientation of these workpieces. For this purpose it is possible to use not only optoelectronic sensors but also pneumatic nozzles. Pneumatic nozzles have the advantage that they are self-cleaning and thus more reliable. A pair of pneumatic signals provide $2^2 = 4$ combinations which can be used to control the further workpiece flow. The example in Fig.a exploits the interruption by a workpiece of the air jet of an air barrier and measures the resulting back pressure. The configuration shown in Fig.b is simpler and utilises back pressure measurement at 2 selected points. An interesting feature is that it is possible to detect not only incorrect orientation but also defective workpieces. This can be seen from the tables above. The choice of technical devices to be used will depend on the overall concept. The trend, however, is towards electrical sensors.

Suitable components:

Gap sensor...
Gap sensor sender nozzle...
Back pressure sensor...
Logic gates with AND and OR functions...
Toggle-lever valve KH...
Fittings
Mounting accessories

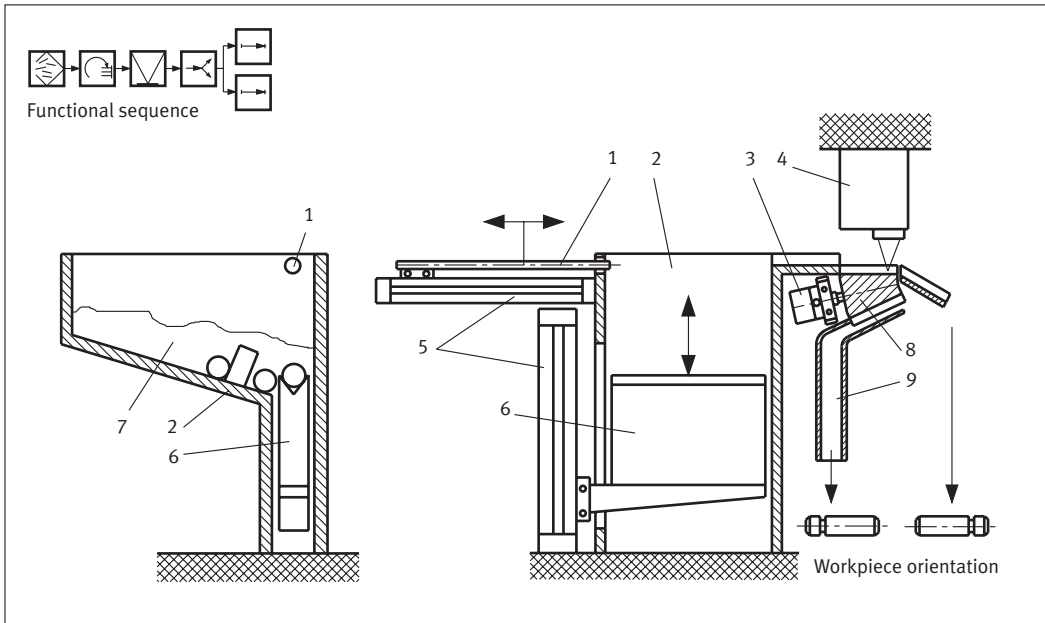

Hopper orientation device

- 1 Pusher rod
- 2 Hopper
- 3 Pneumatic swivel unit
- 4 Camera and video detection system
- 5 Rodless pneumatic cylinder
- 6 Scoop
- 7 Randomly-oriented workpieces
- 8 Rotary distributor
- 9 Output channel

The problem areas during the orientation of workpieces taken from a hopper are always the transition points from the randomly-oriented workpieces to the scoop and from the scoop to the output channel. The example shown above does not rely on the workpieces sliding down an inclined segment by themselves but includes a pusher rod to eject the workpieces from the scoop. At this point, they come to within the field of view of a camera which detects the workpiece orientation and outputs the workpieces separately according to this. A rotary unit is provided for this purpose. This system is flexible within certain limits and can also be used for other similar workpieces. The top edge of the scoop is v-shaped. The length of the scoop should be roughly equal to 5 to 8 times the workpiece length. The ratio of workpiece length to workpiece diameter should be greater than 2:1 to 5:1. In applications with small and short workpieces, it is also possible to use the Festo Checkbox, which allows the optical detection of workpiece features.

Suitable components:

Rodless linear unit DGPL...
 Proximity switch SM...
 Pneumatic single pilot valve...
 Swivel module DSM...
 Checkbox...
 Fittings
 Mounting accessories

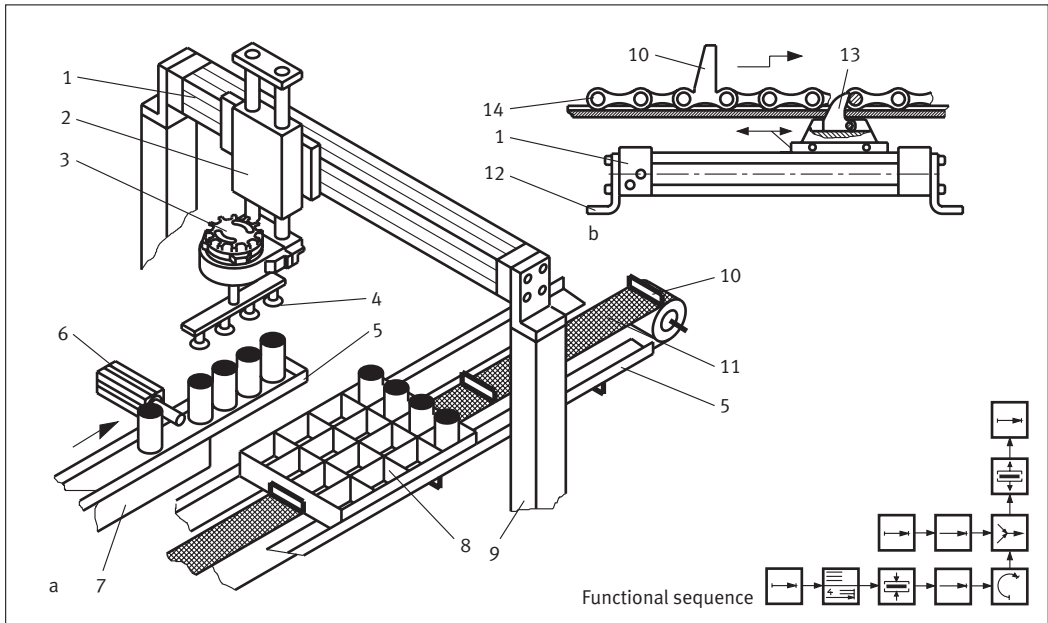

Packing cans

- a) Overall view of installation
b) Feed conveyor belt

- 1 Rodless linear unit
2 Lifting slide
3 Semi-rotary drive
4 Suction cup
5 Lateral guide
6 Stop cylinder
7 Straight vibrating conveyor
8 Packaging material
9 Stand
10 Driver
11 Sectioned conveyor belt
12 Foot
13 Feed pawl

The installation shown is used to pack cans or similar objects in groups. 4 product items are moved at the same time. This allows the use of motion units which are able to approach only end positions. The packaging material is advanced in steps. This can be achieved by using a pneumatic cylinder with a detent which engages in the conveyor chain. It would also be possible to use a semi-rotary drive with a freewheel unit if this is able to deliver sufficient torque. The motion sequence would be essentially the same for an unpacking operation. It would also be the same if mechanical grippers were used instead of suction cups.

Suitable components:

Rodless linear unit DGPL...
Foot mounting HP...
Stopper cylinder STA...
Semi-rotary drive DSR... or DRQD...
Suction cup VAS... or
Fittings
mechanical gripper HG...
Proximity switch SM...
Pneumatic single pilot valve...
Mini-slides SLE... or SLT...

Standard cylinder DSN...
Vacuum generator VAD...
Vacuum efficiency valve ISV...
Mounting accessories

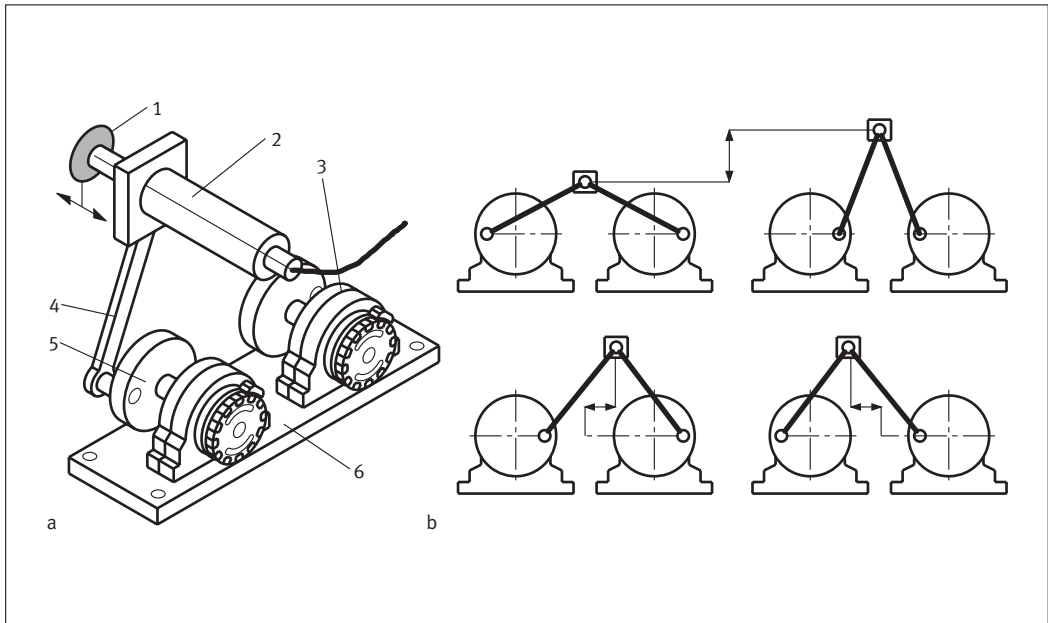

Three-axis positioning unit for small workpieces

- a) Overall view
b) Positioning options with end-position actuators

- 1 End effector (suction cup)
- 2 Pneumatic cylinder
- 3 Rotary unit
- 4 Articulated arm
- 5 Flange
- 6 Base plate

It is also possible to create simple handling devices by using rotary units as axes 1 and 2. The number of achievable positions depends on how many positions each rotary unit permits. If 2 rotary units are used and these can approach only end positions, the number of achievable positions is $2 \times 2 = 4$ positions, as shown in the illustration. The end effector is connected via link rods to the flange discs of the semi-rotary drives. If the connection points are made adjustable, for example by means of elongated holes, this will allow the paths of the end effectors to be varied. For the end effector to be used as a gripper is certainly a special case. This method can be used, for example, to feed a flow of fabric or supply 4 power screwdrivers in turn with only one screw feed. A further advantage is the small size in comparison with other positioning systems and the fast position changing.

Suitable components:

Semi-rotary drive DSR...
Push-on flange FWSR...
Proximity switch SM...
Pneumatic single pilot valve...
Standard cylinder ESN..
Suction cup VAS or gripper HG...
Vacuum generator VAD...
Vacuum efficiency valve ISV...
Fittings, mounting accessories

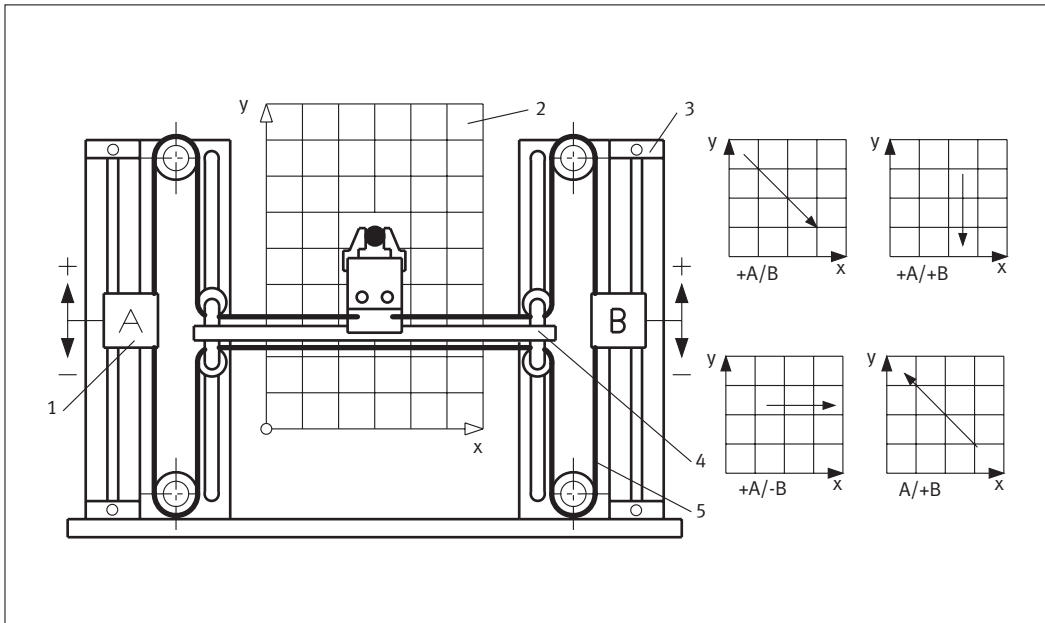

Handling unit with traversing drives

- 1 Slide with clamp pieces to secure toothed belt
- 2 Working area of end effector
- 3 Linear unit as appropriate to positioning requirements
- 4 Horizontal axis guided by twin rollers
- 5 Toothed belt with edge guide rollers

An end effector can be positioned on an X/Y plane by means of traversing drives, as shown in the illustration above. Motion is transmitted to the end effector via toothed belts. The graphs show which drives need to be activated to produce an end effector motion in a given direction. If it is necessary to approach a large number of positions, this naturally requires freely programmable positioning axes. The size and position of the working area are governed by the dimensions of the motion components selected. This principle can be used for both vertical configurations (wall gantries) and horizontal configurations (cross-slide units). The choice of linear guides will depend on the forces involved. The end effector can be any one of various devices, such as a spray gun, power screwdriver, power wrench, drill spindle, labeller or inspection camera. As the drives are fixed and the toothed belts have very low mass, highly dynamic motion sequences can be achieved. For pin-point working, it is advisable to fit additional clamps devices to the slide or horizontal effector guide.

Suitable components:

Positioning drive DGE.. . SP or DGE.. .ZR or pneumatic servo axis DGPI...

Gripper HG...

Multi-axis positioning controller MPS...

Pneumatic single pilot valve...

Mounting accessories

Fittings

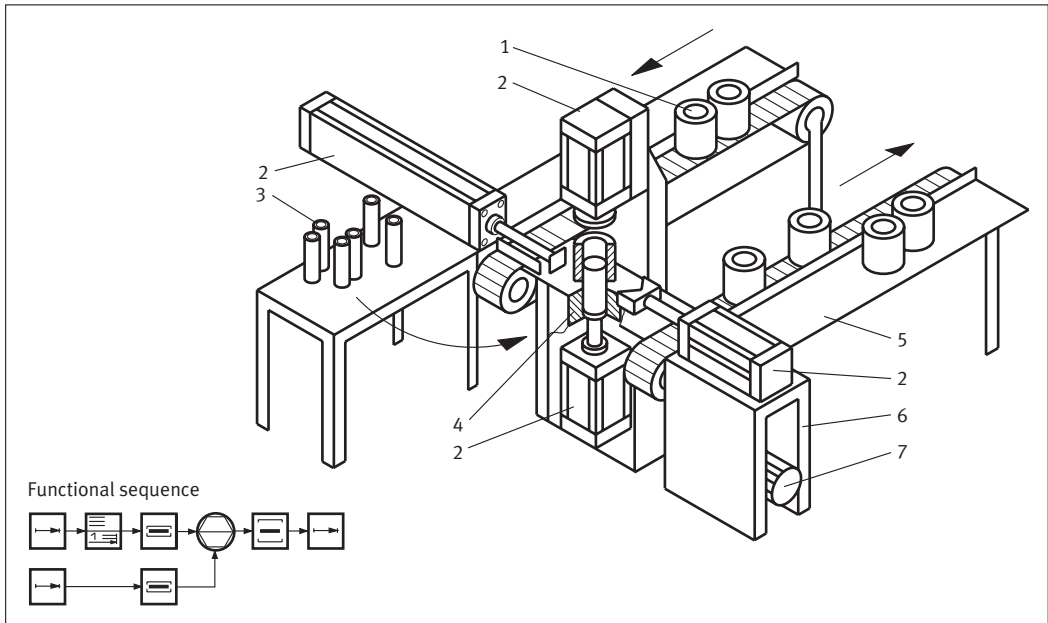

Press-fitting clamp sleeves

- 1 Basic workpiece
- 2 Pneumatic cylinder
- 3 Clamp sleeve (workpiece to be fitted)
- 4 Support table
- 5 Setdown area for finished workpieces
- 6 Conveyor chain drive
- 7 Motor for conveyor

Certain workpieces tend to deform easily during processing and clamping.

In the interests of accuracy and to prevent deformity, these must be fitted with a temporary clamp sleeve to allow further processing. This is achieved by using the system shown above, which is partially automated. The clamp sleeves are first placed into a carrier by hand. The workpiece is then moved into the clamping position against the stop of the more powerful right-hand cylinder. This is followed by longitudinal pressing. After this, the stop cylinder retracts again, allowing the feed cylinder in a second action to push the finished workpiece onto the outward transfer conveyor belt. The clamp sleeves must be removed again after processing has been completed. The workpieces are moved by hand from the conveyors to the side setdown area.

Suitable components:

Flat cylinder DZH...
 Mounting accessories
 Twin cylinder ADVUT...
 Safety start block for two-handed operation
 Pneumatic single pilot valve VL...
 Proximity switch SM...
 Fittings
 Standard cylinder DNC....
 Standard cylinder DNC-Q...
 Foot mounting HNG...

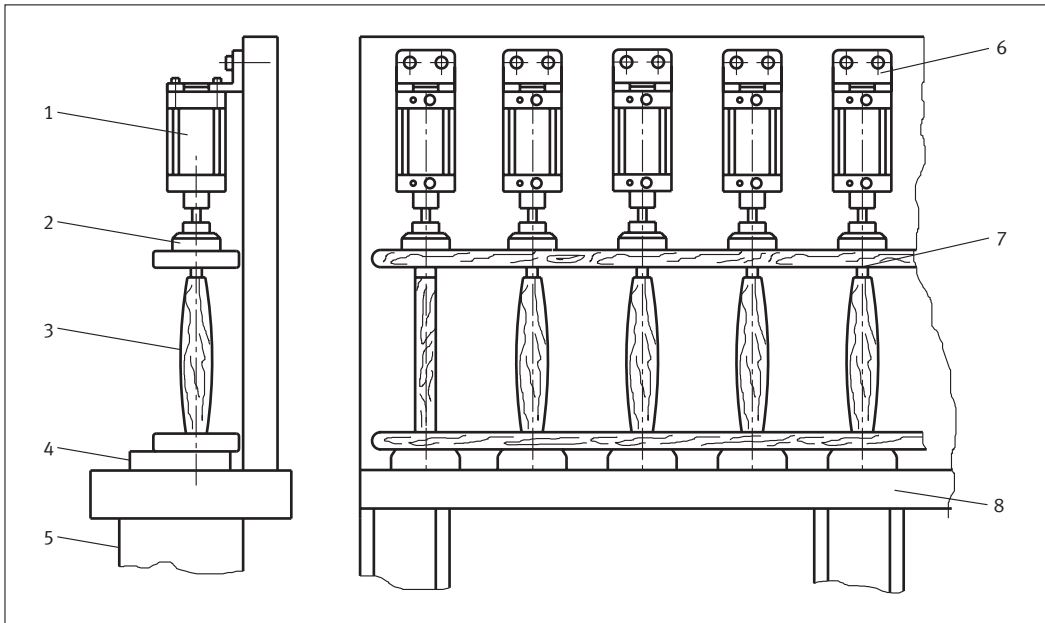

Press-fitting ladder rungs

- 1 Pneumatic cylinder
- 2 Pressure pad
- 3 Wooden rung
- 4 Support
- 5 Frame
- 6 Foot mounting
- 7 Ladder side piece
- 8 Press table

Aluminium-profile ladders are becoming more and more popular, but traditional wooden ladders are nonetheless still being produced. An appropriate number of pneumatic cylinders can be used to press-fit the rungs evenly. In order to carry this out successfully, it is important that the workpieces (the rungs) to be press-fitted should be positioned reasonably straight. It is therefore useful to have holding devices made of spring steel. The jig used for this operation is very simple and can be used as a model for other similar operations. The multi-cylinder array means that the press can, for example, be used as a body clamp for joinery and furniture-making. Provision of universal use of this kind will be made at the design stage in the form of adjustment facilities, for example a drilled grid panel for the mounting of the pneumatic cylinders or a facility for the fitting of side brackets to allow the mounting of further press cylinders.

Suitable components:

Standard cylinder DNG... or twin cylinder ADVUT...
 Proximity switch SM...
 Pneumatic single pilot valve VL...
 Foot mounting HNG...
 Safety start block for two-handed operation
 Mounting accessories
 Fittings

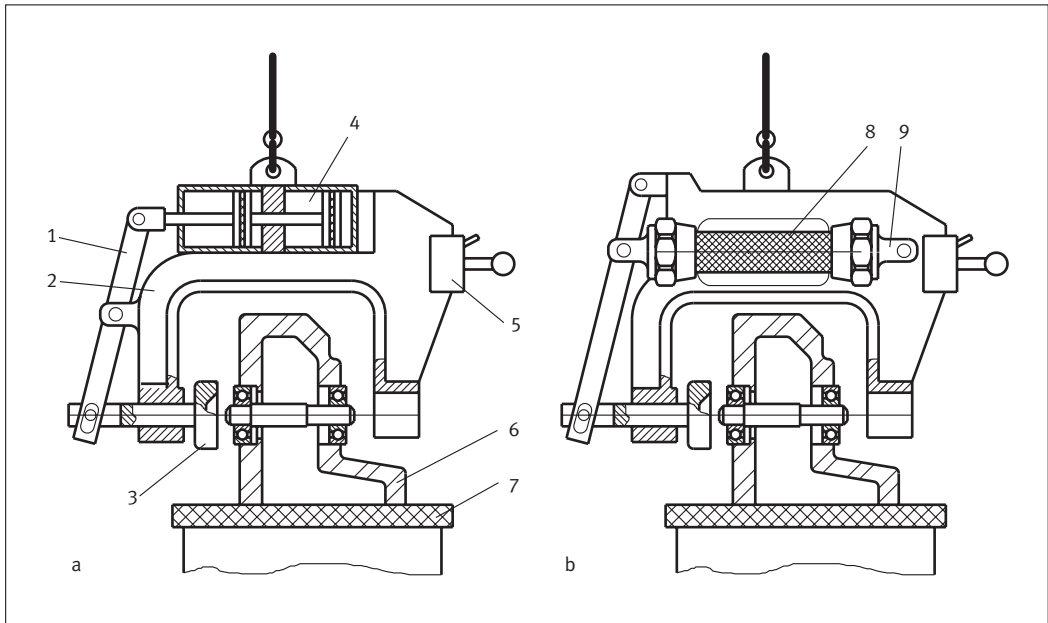

Mobile pneumatic press-fitting unit

- a) Driven by twin cylinder
- b) Driven by Fluidic Muscle

- 1 Lever
- 2 C frame
- 3 Pressure plate
- 4 Pneumatic cylinder
- 5 Hand control and guide unit
- 6 Basic assembly component
- 7 Support table
- 8 Fluidic Muscle
- 9 Muscle mounting

Assembly work on large workpieces, for example the press-fitting of all kinds of bearings, is often carried out with stationary workpieces, i.e. away from assembly transfer systems. The same is often true of repair operations. Assembly presses must therefore come to the workpieces and are accordingly mobile and suspended from a hoist. The pressure cylinder is integrated into the press bracket and applies force to the pressure plate via a lever. Force flows in a closed loop through the bracket to the opposed support. It is also possible to use the new Fluidic Muscle instead of a conventional pneumatic cylinder. This reduces the mass of the assembly press, allowing it to be moved in 3 dimensions with less force. The example on the right above also includes a second Fluidic Muscle installed in parallel and behind the first one and thus not visible in the illustration. Dismantling operations can also be carried out with this unit if suitable tools are fitted.

Suitable components:

Twin cylinder ADVUT...
 Proximity switch SM...
 Pneumatic single pilot valve...
 Safety start block...
 Fluidic Muscle MAS...
 Rod clevis SG...
 Mounting accessories
 Fittings

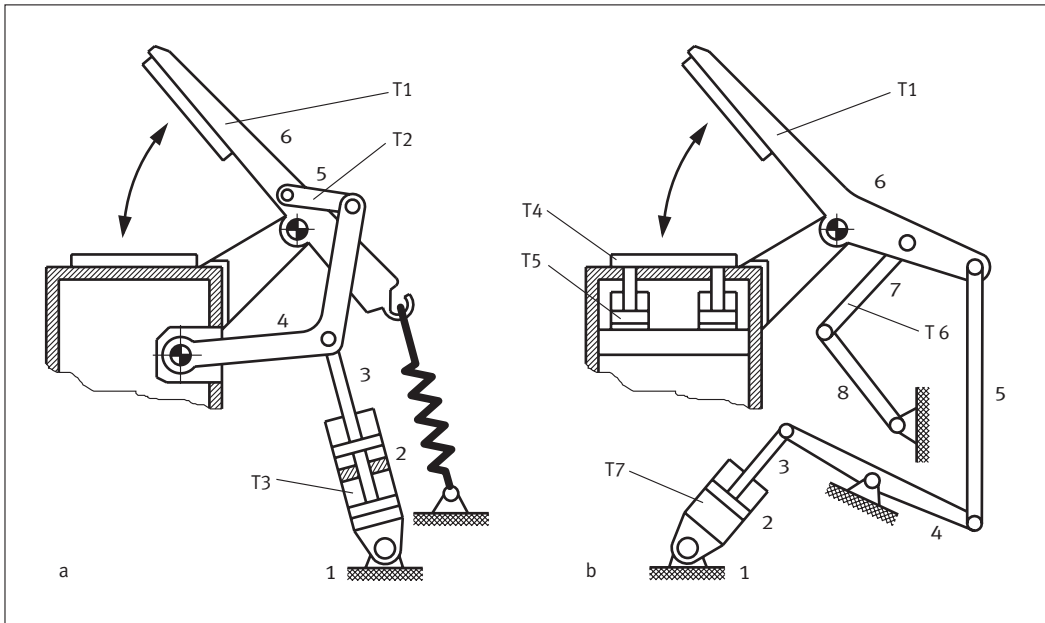

Hinged presses for textiles

- a) Clothes press
- b) Tacking press

- T1 Press arm, if appropriate with shaped press shoe
- T2 Link arm
- T3 Twin pneumatic cylinder
- T4 Press table
- T5 Pressure cylinder
- T6 Toggle-lever mechanism
- T7 Pneumatic cylinder

- 1 to 8:
Links in the kinematic chain

Many different presses are used in the textile industry for smoothing, ironing and tacking. A typical feature of these devices is the link mechanism which are used in order to achieve a certain motion sequence. For example, upper pressure plates are required to open wide and quickly, while in their working positions presses are required to provide an even pressure right across their working surface. The solution shown in Fig. a uses a 6-link mechanism to transmit the motion of the power cylinder to the press plate. The opening angle is 70°. In the case of the press shown in Fig. b, links 7 and 8 form a toggle lever. This eliminates backlash within the mechanism when this is fully extended and fixes the horizontal position of the upper plate. Only then is the power cylinder activated to push together the press table and upper plate and thus complete the pressing operation.

Suitable components:

Twin cylinder ADVUT...
 Fittings
 Pneumatic single pilot valve...
 Pneumatic cylinder ADVU...
 Proximity switch SM...
 Rod clevis SG...
 Swivel flange SUA...
 Clevis foot mounting LN...
 Mounting accessories

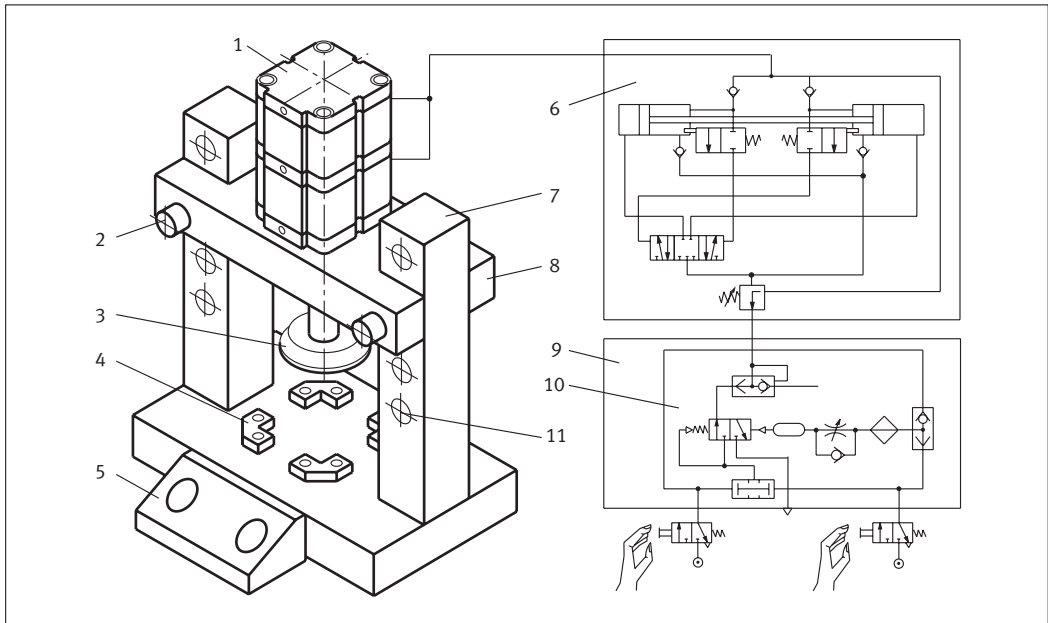

Small pneumatic press

- 1 Pneumatic cylinder
- 2 Movable pin
- 3 Pressure plate
- 4 Positioning aid for basic assembly components
- 5 Control panel with two-handed start
- 6 Pressure booster
- 7 Column
- 8 Adjustable yoke plate
- 9 Control block for two hand start
- 10 Shuttle valve circuit
- 11 Hole to accept movable pin

Longitudinal pressing is a relatively common operation within assembly work, for which manual or manually-fed assembly presses are used. In very many cases, pneumatic presses will be fully adequate, especially if twin cylinders are used together with an operating pressure >6 bar. A press of this kind is shown in the illustration above. The height of the press yoke can be adjusted by means of movable pins. The operating pressure is provided by a pressure booster. In the case of manually-fed presses, a two-handed safety start block should be fitted.

Suitable components:

Twin cylinder ADVUT... or compact cylinder AEVU...
 Pressure booster...
 Safety start block...
 Proximity switch SM...
 Basic valve SV...
 Actuator P...
 Mounting accessories
 Fittings

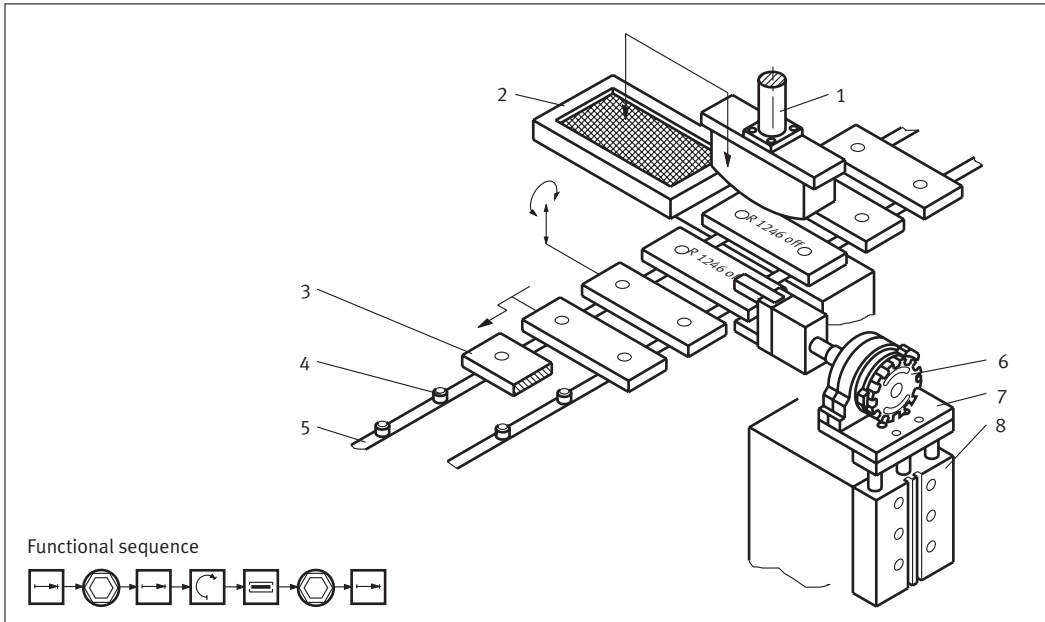

Device for double-sided tampon printing

- 1 Tampon plunger
- 2 Stencil
- 3 Workpiece
- 4 Carrier pin
- 5 Indexed chain conveyor
- 6 Swivel unit
- 7 Adapter plate
- 8 Lifting unit

Manual methods are still frequently used to print workpieces using the tampon printing method. Automation therefore always brings a considerable rationalisation effect and also produces a more even printed result. In order to achieve good-quality printing, the ink must be transferred from the stencil to the workpiece as quickly as possible. Forces of more than 1000 N are often required for the printing operation. In the solution shown here, the workpiece, which has already been printed on one side, moves between the gripper jaws, which then close. The workpiece is then lifted off the transfer system, turned and set down again on the carrier pins. With the next workpiece, the gripper turns back again. The printing process is then repeated at a second station. In the printing station, the workpiece is lifted slightly away from the chain conveyor to prevent overloading it. Incidentally, the positioning accuracy for double-sided printing must be better than ± 0.01 mm.

Suitable components:

- Guided drive DFM...
- Proximity switch SM...
- Parallel gripper HGP...
- Pneumatic single pilot valve VL... or single solenoid valve MFH...
- Adapter kit HAPG...
- Mounting accessories
- Semi-rotary drive DSR... or swivel unit DSM...
- Fittings

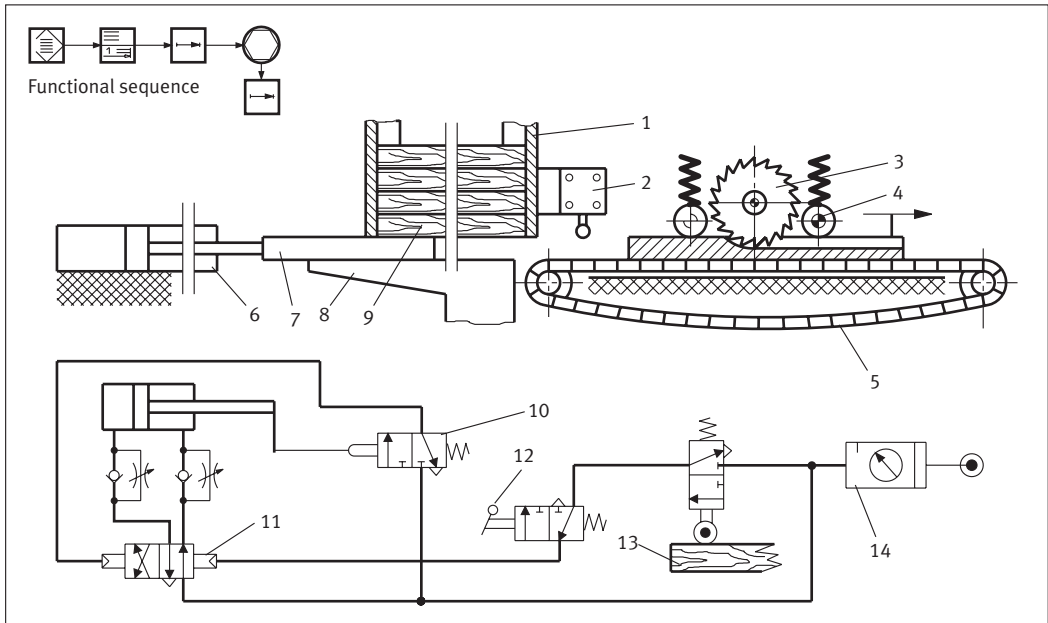

Moulding router with magazine device

- 1 Strip magazine
- 2 Roller feeler
- 3 Profile router
- 4 Pressure roller
- 5 Conveyor chain
- 6 Pneumatic cylinder
- 7 Slide
- 8 Straight slide guide
- 9 Stack of wood strips
- 10 Directional control valve
- 11 Double pilot valve
- 12 Finger lever valve
- 13 Wood strip
- 14 Service unit

In the woodworking industry, mouldings are often produced by routing cutters in continuous throughput operation. This operation can easily be automated, since it is only necessary to make provision for the regular input of working material. The remaining machine functions will then only require the attention of 0.3 operators. The strip material is fed from a stack magazine, which is filled manually. The feed device (insertion cylinder) is activated when the roller lever valve enables the feed of the next wood strip. After the strip has been inserted, it is conveyed by a caterpillar chain. The return stroke of the feed slide is triggered by a cam valve. This can also be achieved by electrical means by using a proximity switch. After machining, the workpieces can be returned to a second stack magazine if desired. These two magazines should be adjustable to allow them to accept workpieces of different lengths.

Suitable components:

Standard cylinder DNC...
 3/2-way valve...
 4/2-way valve...
 Service unit...
 One-way flow control valve...
 Proximity switch SM...
 Self-aligning rod coupler FK...
 Mounting accessories, fittings

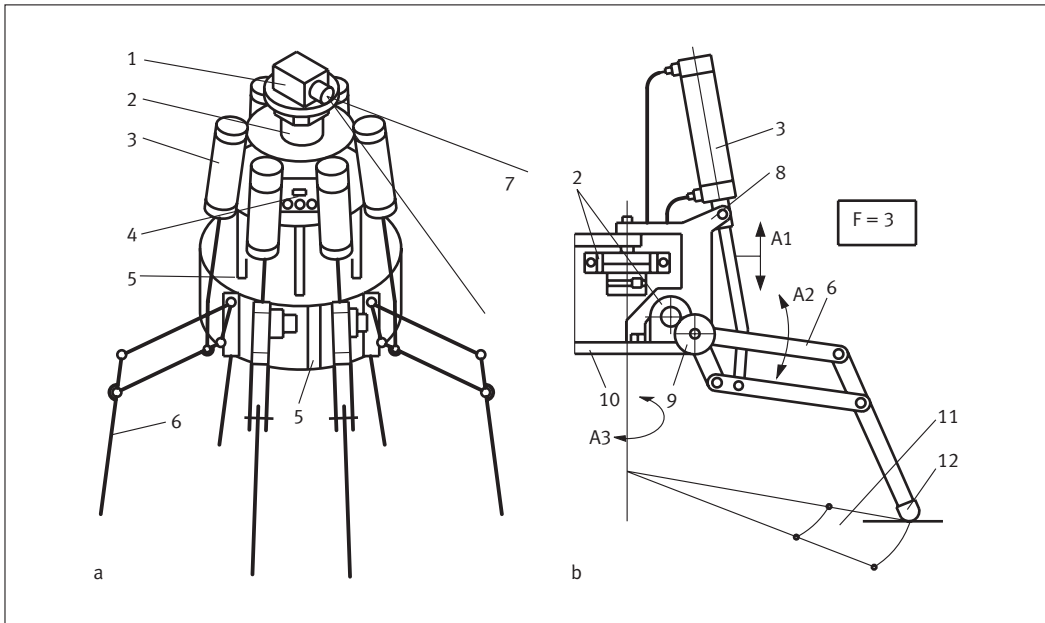

Self-propelled machine of hexapod design

a) Overall view (simplified) b) Leg design

- 1 Camera
- 2 Rotary unit
- 3 Pneumatic cylinder
- 4 Controller
- 5 Support
- 6 Pantograph gear unit
- 7 Field of view
- 8 Leg swivel segment
- 9 Gearwheel
- 10 Support plate
- 11 Range of possible foot contact points
- 12 Foot

- A Axis
F Degree of freedom

Pneumatic components are frequently used to create equipment for research, simulation and training purposes. This six-legged insect-like self-propelled robot (produced to the design of Baudoin of Brussels) externally resembles the ODEX self-propelled machine made by Odetics of California. The machine is used to study robot/human being interactions in the process of stepping over obstacles. As each of the machine's legs can execute 3 driven motions, the machine has an overall degree of freedom $F = 18$. Vertical and horizontal leg motions are separate, and several types of locomotion are possible. Flow control valves are used to adjust each swivel cylinder to produce a smooth motion. The machine is also equipped with a video detection system which allows it to navigate by itself. Possible applications include the military field and work in contaminated environments.

Suitable components:

Swivel cylinder DSR...
Flow control valve GRLA...
Proximity switch SM...
Round cylinder DSW...
Clevis foot mounting SBS...
Pneumatic single pilot valves...
Mounting accessories
Fittings

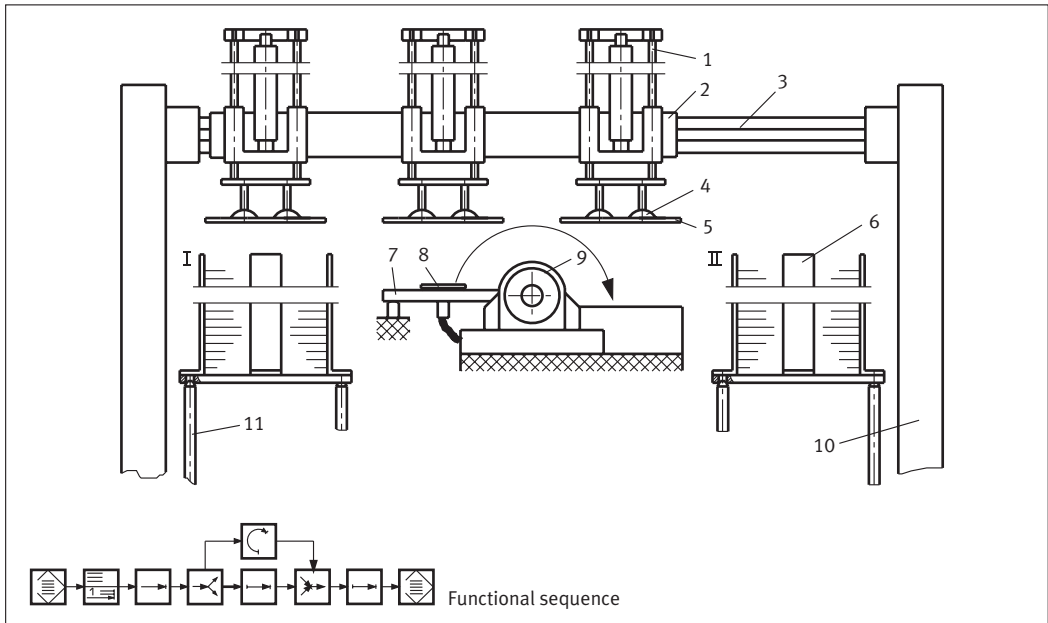

Device for re-sorting into alternate layers

- 1 Guide unit
- 2 Slide
- 3 Rodless linear unit
- 4 Suction cup
- 5 Workpiece
- 6 Stack magazine
- 7 Turnover vane
- 8 Oval suction cup
- 9 Rotary unit
- 10 Stand
- 11 Magazine station

There is occasionally the requirement, either as a preliminary stage in a packing process or for technological reasons, to sort workpieces into alternate layers. This is achieved in the example shown by a stepwise transfer operation in which every second workpiece is turned over. The flat workpieces are removed one at a time from magazine I, and set down on the turnover vane. From here, they are picked up and set down again before entering magazine II in a third and final step. Every second workpiece, however, is transferred by the turnover vane itself and is thus inverted. To ensure that workpieces do not fall off the turnover vane, they are held to this by vacuum. At the end of the transfer process, the workpieces are stacked in magazine II front face to front face and rear face to rear face. All the necessary movements can be achieved using standard pneumatic components. The workpieces are handled in a way which prevents damage. The stroke of the vertical units is sized such that they are able to reach right down to the bottom of the magazines.

Suitable components:

Rodless linear unit DGPL...
 Standard cylinder DNC... and guide unit FEN...or DFM..
 Vacuum efficiency valve ISV..., Vacuum generator VADM...
 Pneumatic single pilot valve... or valve terminal CP...
 Proximity switch SM...
 Swivel unit DSR..., Suction cup VAS..., oval suction cup
 Mounting accessories, fittings

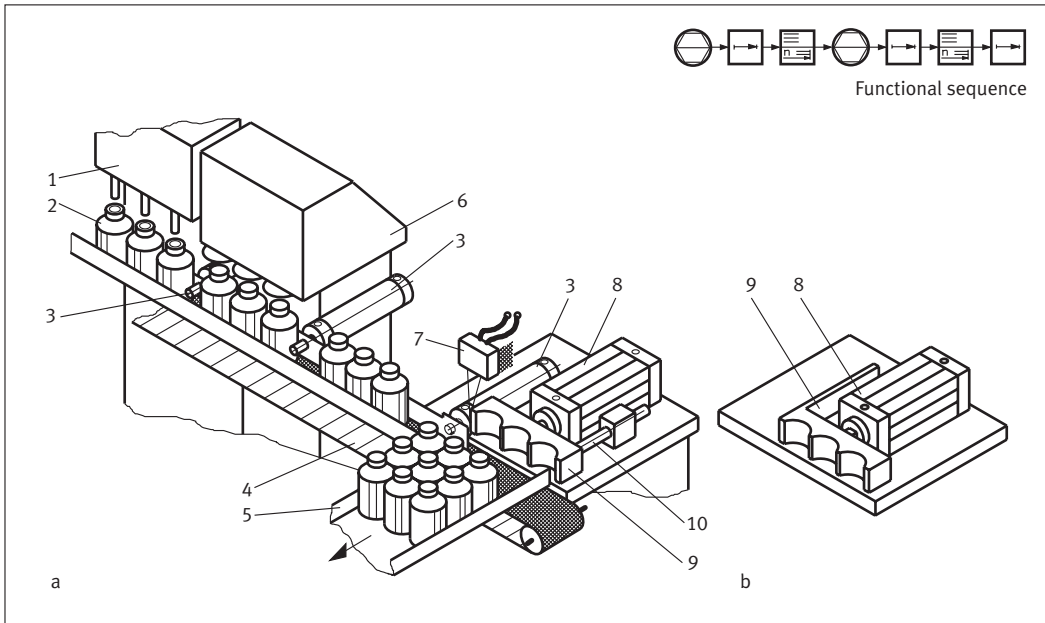
**Bottle re-positioning device**

- a) Overall view of installation
 b) Variant using a non-rotating piston rod

- 1 Filling station
- 2 Beverage bottle
- 3 Stop-slide cylinder
- 4 Conveyor belt
- 5 Lateral accumulation zone
- 6 Multiple closure device
- 7 Sensor
- 8 Pneumatic cylinder
- 9 Ejector slide
- 10 Protection against torsion

The transfer of workpieces from one system section to another is often combined with the formation of new setdown patterns, for example as a necessary preparation for packing. The illustration shows how bottles pass through workstations in groups of 3 and are then, still in these groups, pushed onto a lateral accumulation zone. The lateral ejection operation is started when the sensor confirms that a complete group of 3 bottles has arrived. It may be possible to eliminate the need for a stop slide if the ejector slide is also able to provide this function (Fig. b). A further design simplification can be achieved by using drive cylinders with non-rotating piston rods or oval pistons.

Suitable components:

Standard cylinder ESN... or flat cylinder DZF...
 Compact cylinder AEVU... or AEVULQ...
 Proximity switch SM...
 One-way flow control valve GR...
 Diffuse sensor SOEG...
 Mounting accessories
 Fittings

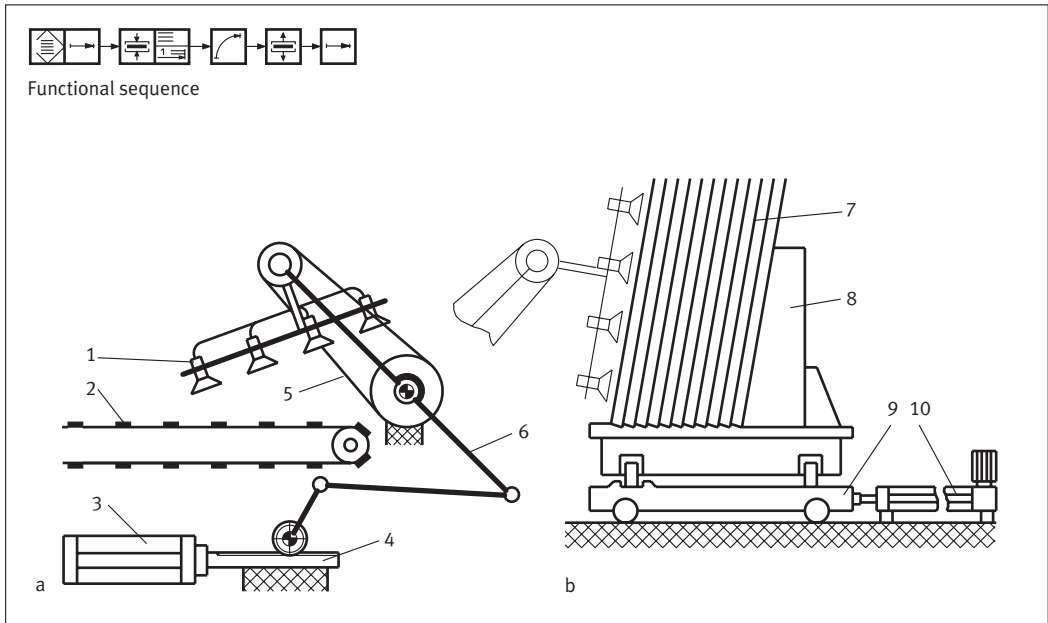

Device to re-position sheet glass

- a) Stationary transfer device
b) Sheet-glass trolley

- 1 Suction cup frame
- 2 Dimpled setdown conveyor belt
- 3 Drive cylinder
- 4 Rack-and-pinion mechanism
- 5 Non-driven toothed belt or chain
- 6 Guide mechanism
- 7 Stack of sheet glass
- 8 Transport trolley with workpiece rack
- 9 Lateral sliding platform
- 10 Positioning axis

This transfer device for sheet glass utilises a guide mechanism which consists of a four-link crank with a traction unit. As the toothed belt is not driven but is fixed, a motion of the guide arm causes the suction cup frame to swivel from the pick-up position to the setdown. The stack of sheet glass is moved up step by step by a positioning drive. The lateral sliding platform is recessed into the floor. The glass transport trolley is pushed onto this platform, guided by a rail. There are other design solutions which can provide a swivel motion, such as rotary units used singly or in pairs.

Suitable components:

Standard cylinder DNC... or rotary drive DRQ... or electrical positioning axis DGE...SP with single-axis positioning controller EPS...
 Vacuum efficiency valve ISV...
 Height compensator VAL...
 Suction cup VAS...
 Proximity switch SM...
 Pneumatic single pilot valve...
 One-way flow control valve GR...
 Vacuum pump
 Mounting accessories
 Fittings

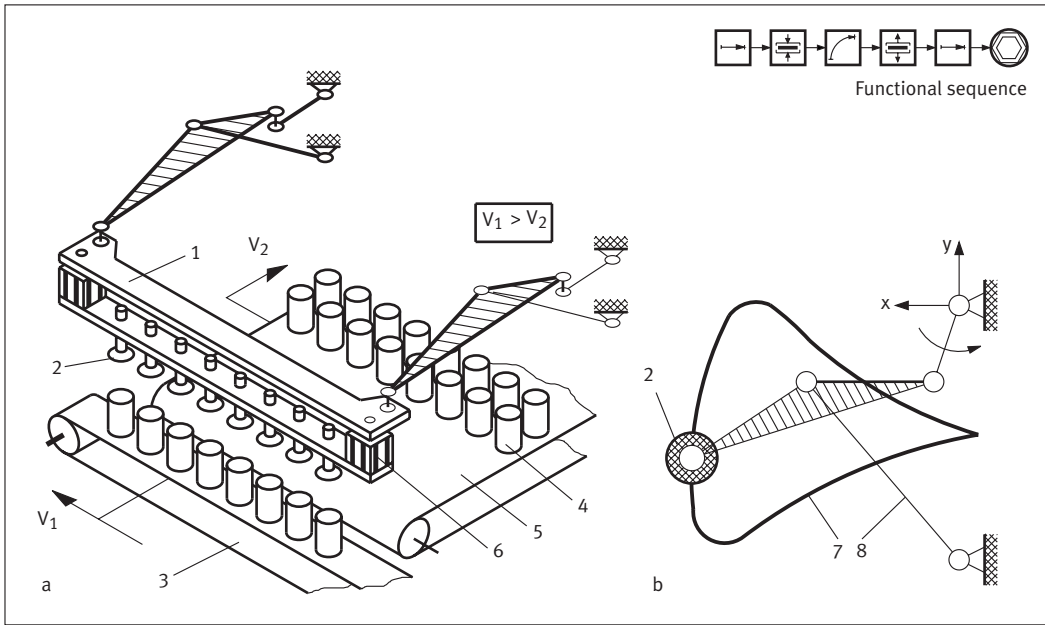

Tin-can transferring device

a) Schematic representation of transfer system

b) Four-link mechanism (plan view)

- 1 Conveyor beam
- 2 Suction cup
- 3 Feed conveyor belt
- 4 Workpiece (can)
- 5 Outfeed conveyor belt
- 6 Lifting cylinder
- 7 Link cam
- 8 Articulated arm

Even in the age of electronically controlled drives, mechanical transfer devices with a non-uniform action still have their uses, thanks to the high repetition accuracy which they offer together with their low investment cost. The example above shows an application in which cans are transferred in groups from one conveyor belt to another which is running significantly slower. The cans are picked up by their tops via suction cups, which means that it is permissible for their other exterior surfaces to have areas of wet ink or paint. The overall device has been designed as a dedicated solution and has only limited flexibility. Instead of the short-stroke power cylinder, it would also be possible to use special lifting suction cups. These are units in which a piston drives a suction cup onto a workpiece and then lifts this once vacuum has built up under the cup.

Suitable components:

Bellows suction cup VASB...or lifting suction cup
 Vacuum generator VAD... or vacuum generator with ejector pulse VAK...
 Vacuum efficiency valve ISV...
 Compact cylinder ADVU...
 Proximity switch SM...
 Mounting accessories and fittings

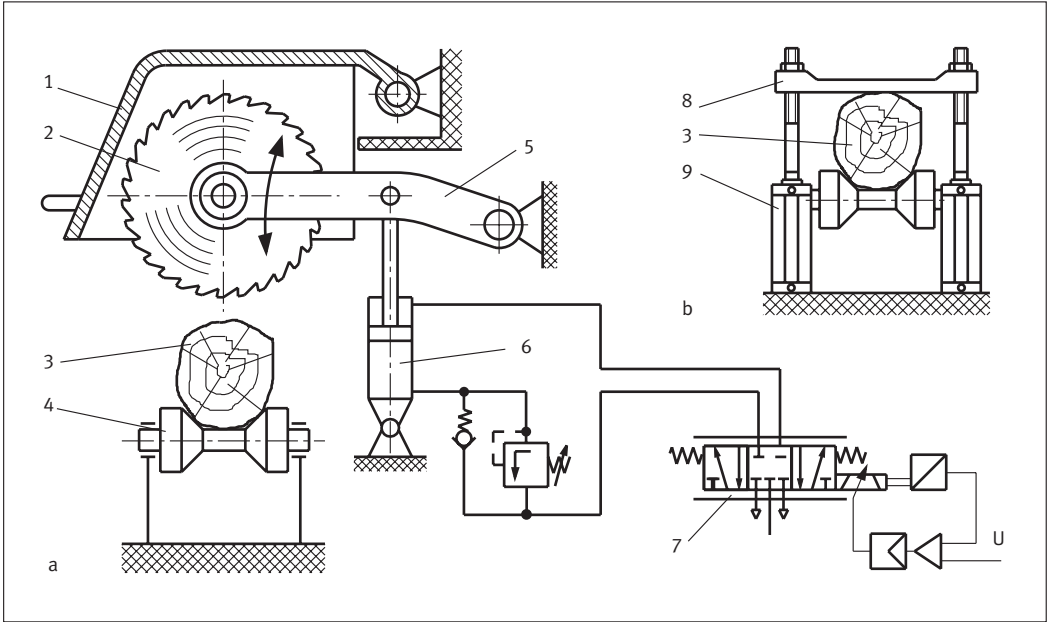

Swing saw for round timber

- a) Design principle of swing saw
- b) Clamping device

- 1 Safety guard
- 2 Saw blade
- 3 Tree trunk
- 4 Roller conveyor
- 5 Swivel arm
- 6 Power cylinder
- 7 Proportional valve
- 8 Clamping bridge
- 9 Pneumatic cylinder

Fluid power drives have proved ideal for use in the woodworking industry thanks to their robust design, although hydraulic drives are frequently used. For applications such as X/Y positioning, clamping, guiding and moving of wood workpieces and tools, pneumatic actuators can also be used to good effect. The invaluable advantages of pneumatics are the fast actuating times offered and the non-flammability of the medium involved. One example of this is the swing saw shown above. This is used to cut round timber to specified lengths. The arm is swivelled by a single pneumatic cylinder or by two cylinders arranged in parallel. If extra power is required, a pressure booster can also be used.

Suitable components:

- Standard cylinder DNG... or DNC...
- Proportional valve MPYE...
- Clevis foot mounting LBG...
- Rod eye SGS...
- Compact cylinder ADVU...
- Pressure regulator LR...
- Non-return valve H...
- Proximity switch SM...
- Pneumatic single pilot valve...
- Pressure booster...
- Mounting accessories, fittings

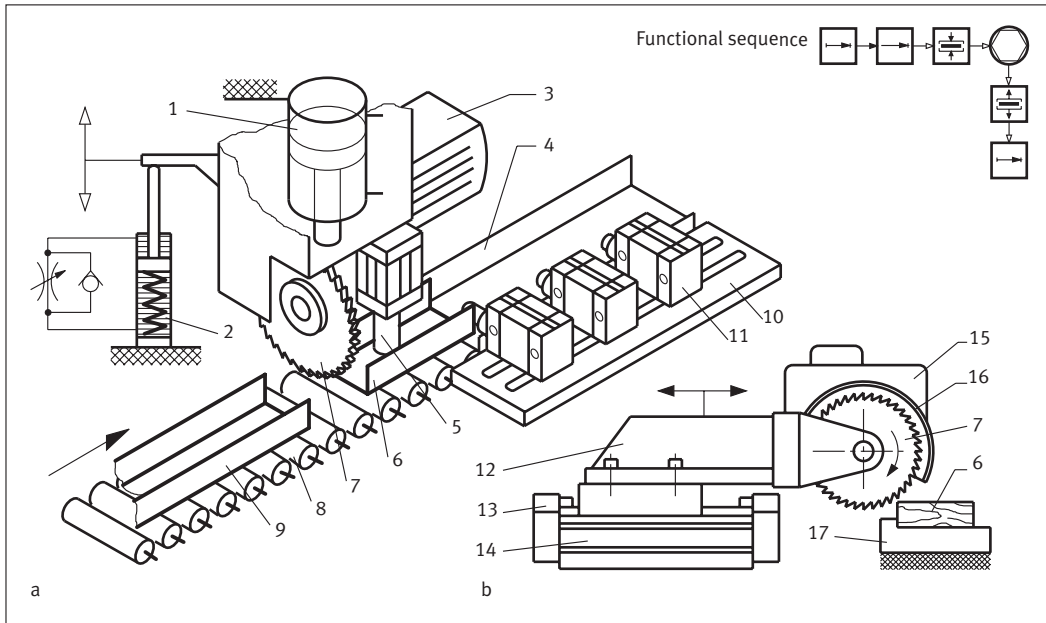

Sawing aluminium and plastic profiles

- a) Vertically guided saw
b) Horizontally guided saw

- 1 Feed cylinder
- 2 Hydraulic cushioning cylinder
- 3 Saw motor
- 4 Lateral guide
- 5 Clamping component
- 6 Workpiece
- 7 Saw blade
- 8 Roller conveyor
- 9 Profile rod
- 10 Carrier plate
- 11 Stopper cylinder as fixed-length stop
- 12 Support block
- 13 Linear unit
- 14 Shock absorber
- 15 Saw unit
- 16 Safety guard
- 17 Workpiece carrier

It is often necessary to produce small quantities of blank workpieces in standard lengths. These may be produced from solid or hollow profile stock of various cross-sections and materials. The example above shows a saw unit in which a saw blade is guided vertically while a hydraulic cushioning cylinder installed parallel to this provides cushioning and braking functions. The stops used are stopper cylinders, set to a range of frequently required standard lengths. Before sawing is carried out, the profile bar is clamped; the length to be cut off is usually also clamped. As can be seen in Fig.b, it is also possible to fit a saw unit to an arm which advances horizontally. The arm in this case is generally hydraulically driven. Given suitable conditions and design measures, it is also possible to use a drive combination consisting of a pneumatic cylinder, hydraulic cushioning cylinder and pressure booster.

Suitable components:

Compact cylinder ADVU...
Hydraulic cushioning cylinder YDR...
Pneumatic linear unit DGPL...HD
Stopper cylinder STA...
Proximity switch SM...
Standard cylinder DNC...
Pneumatic directional control valve...
Mounting accessories, fittings

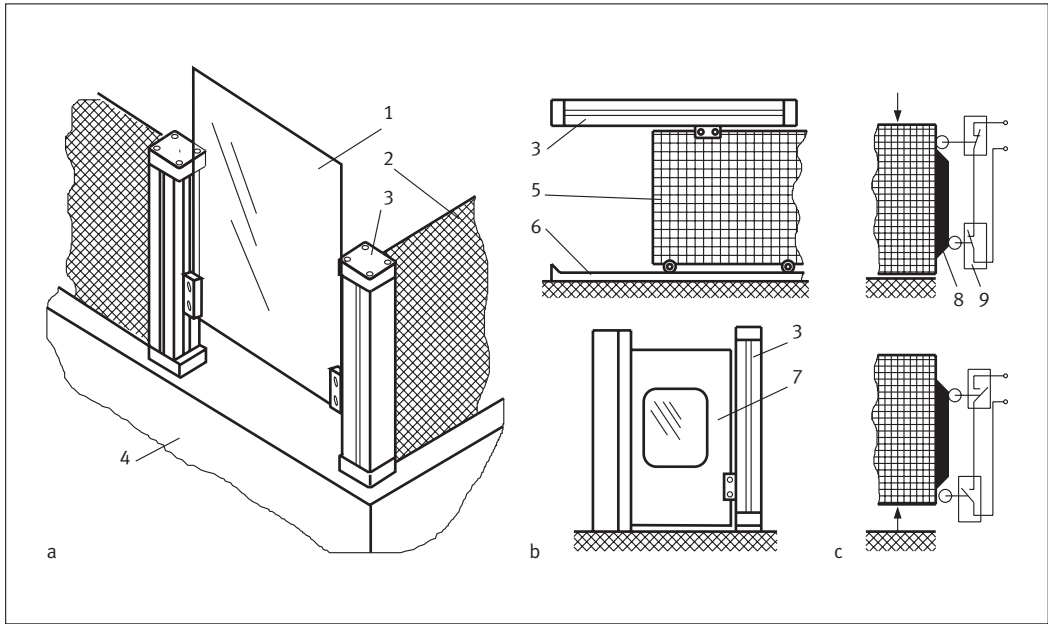

Movable safety guards

- a) Lift-up safety guard
- b) Sliding grille and lift-up door
- c) Safety circuit.
Top: Circuit closed.
Bottom: Circuit open

- 1 Synthetic glass screen
- 2 Wire grille
- 3 Rodless pneumatic cylinder
- 4 Machine table or floor
- 5 Sliding grille
- 6 Guide rail
- 7 Lift-up door with inspection window
- 8 Switch cam
- 9 Contact switch

Large safety grilles to give whole-body, hand or arm protection and safety windows to guard against flying chips can be opened and closed quickly using rodless cylinders, particularly when large distance or strokes need to be covered. All relevant accident-prevention regulations should be observed at all times. In the case of low-risk applications, adequate protection can be achieved by using interlock devices based on a one position monitoring sensor. If the risk is higher, the number of components must be doubled, which means 2 sensors are required. These provide separate monitoring of the open and closed door positions. In the case of lift-up safety grilles, the rodless linear unit involved can also be equipped with a clamping unit. This is activated under pressure-less conditions and also in cases of pressure supply failure. This ensures that a safety grille which has been raised cannot fall due to a power supply failure.

Suitable components:

- Rodless linear unit DGP...
- Clamping unit DGPK...
- Proximity switch SM...
- Pneumatic single pilot valve...
- Foot mounting HP...
- Mounting accessories
- Fittings

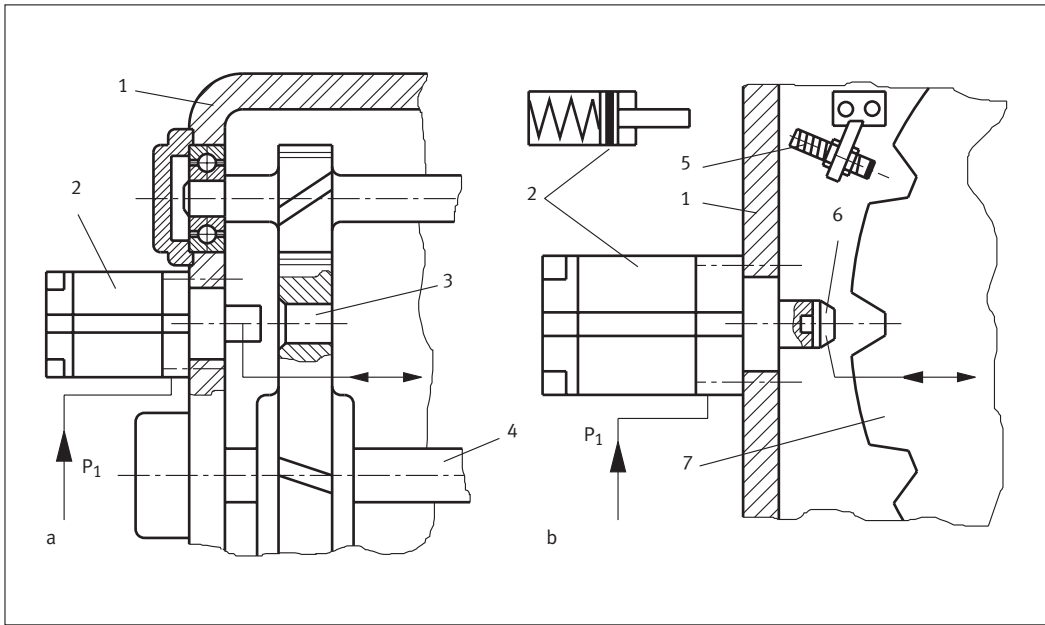

Locking the position of moving components

- a) Transmission lock
- b) Detenting an indexing disc

- 1 Transmission housing
- 2 Stopper cylinder
- 3 Pinion with detent hole
- 4 Shaft
- 5 Inductive proximity sensor
- 6 Tapered detent pin
- 7 Indexing disc

P₁ Compressed air

Thanks to their reinforced piston rods, stopper cylinders can also be used to good effect for locking functions. In the solution shown in Fig.a, the gear transmission remains operational as long as a power supply is present and the cylinder piston rod is retracted. If the power supply fails, spring force causes the piston rod to advance and lock the transmission. The speed at which the lock engages depends on the number of detent holes present. The gearwheel selected for use as a locking wheel within the transmission should be one which transmits only a low torque value. Another similar application is the securing of loads which have been lifted and are held in a shaft, using for example 4 stopper cylinders at 90° intervals. In the case of the solution shown in Fig.b, the piston rod carries an adhesive-bonded hardened tapered pin, which engages in the v-shaped slots of the indexing disc in order to lock this. The signal to activate this device is provided by a proximity sensor. Stopper cylinders can be mounted in various different ways as appropriate to a given situation.

Suitable components:

- Stopper cylinder STA...
- Pneumatic single pilot valve...
- Proximity switch SM...
- Proximity switch SIE...
- Foot mounting FV...
- Mounting accessories
- Fittings

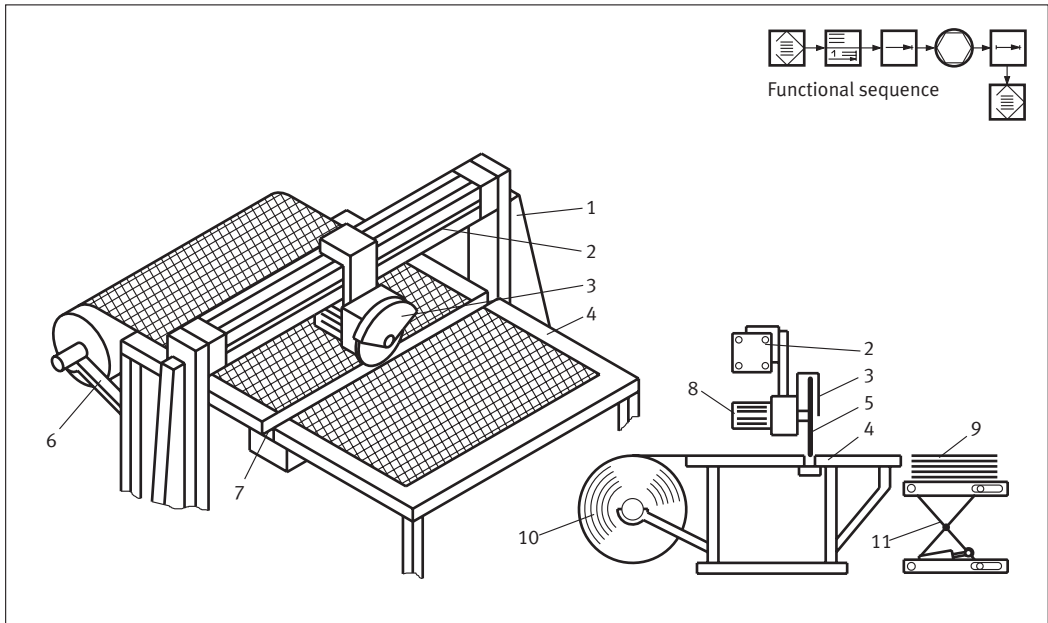

Lateral cut-off device for textiles

- 1 Stand
- 2 Rodless linear unit
- 3 Cutter unit
- 4 Support table
- 5 Circular cutter
- 6 Support arm for textile roll
- 7 Connector
- 8 Electric motor
- 9 Setdown table for cut pieces
- 10 Textile roll
- 11 Scissor-tong table

There is a need not only in the textile industry but also in mechanical engineering in general to separate or cut-off textiles, carpeting, technical textiles, etc. A remarkably simple device for this purpose is shown in the example above. The cutter unit is moved laterally by a rodless cylinder, the speed of which can be adjusted by exhaust-air flow controls. The principle of unrestricted supply air and throttled exhaust air means that the piston is clamped evenly between air cushions, which also improves its running characteristics. A somewhat higher speed can be used for the return of the slide to its initial position. The textile roll is suspended from the support arm and material is pulled from this by hand. The circular cutter runs in a slot in the support table. The withdrawal of material from the roll could also be automated but would be worthwhile only if large quantities of cut pieces are required. A roller or gripper feed device would be suitable for this purpose.

Suitable components:

Rodless linear unit DPGL...or electromechanical axis DGE...ZR with single-axis positioning controller EPS...

Proximity switch SM...

One-way flow control valve GR...

Pneumatic single pilot valve...

Mounting accessories

Fittings

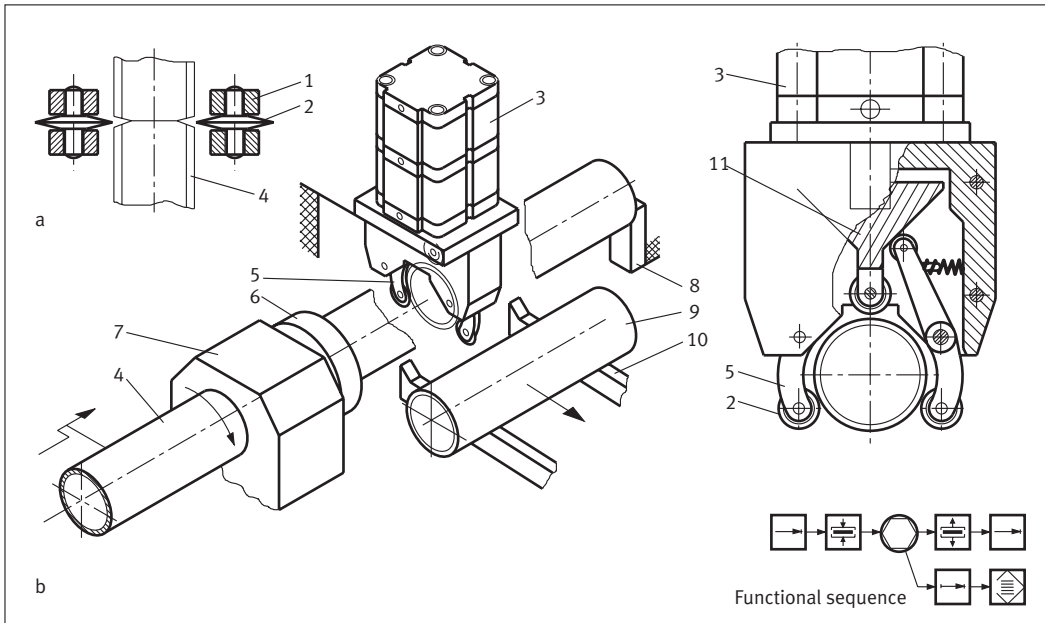

Cutting thin-walled pipe

- a) Operating principle
b) Simplified overall view

- 1 Cutter wheel bearing
- 2 Cutter wheel
- 3 Tandem cylinder
- 4 Pipe
- 5 Lever arm for cutter wheel
- 6 Chuck
- 7 Hollow spindle drive
- 8 Adjustable stop
- 9 Finished pipe section
- 10 Roller conveyor
- 11 Tapered piece

Thin-walled piping can be cut with cutter wheels without wastage. Governed by the cutter design, chipless separation is achieved through a wedge-shaped cut, produced by driving the three cutter wheels towards the centre of the pipe. Two of the cutter wheels are mounted on levers which are driven via a wedge. Their motion is derived from the main motion of the power cylinder. The three cutter wheels are thus brought together by purely mechanical means. The feed speed is controlled by exhaust-air throttling. The pipe is in each case pushed through the chuck up to the stop. After cutting, finished tubing sections are output onto a roller conveyor. The required drive power is provided by a power cylinder of suitable size or, as shown above, a tandem cylinder.

Suitable components:

Tandem cylinder ADVUT...
One-way flow control valve GR...
Proximity switch SM...
Pneumatic single pilot valve...
Mounting accessories
Fittings

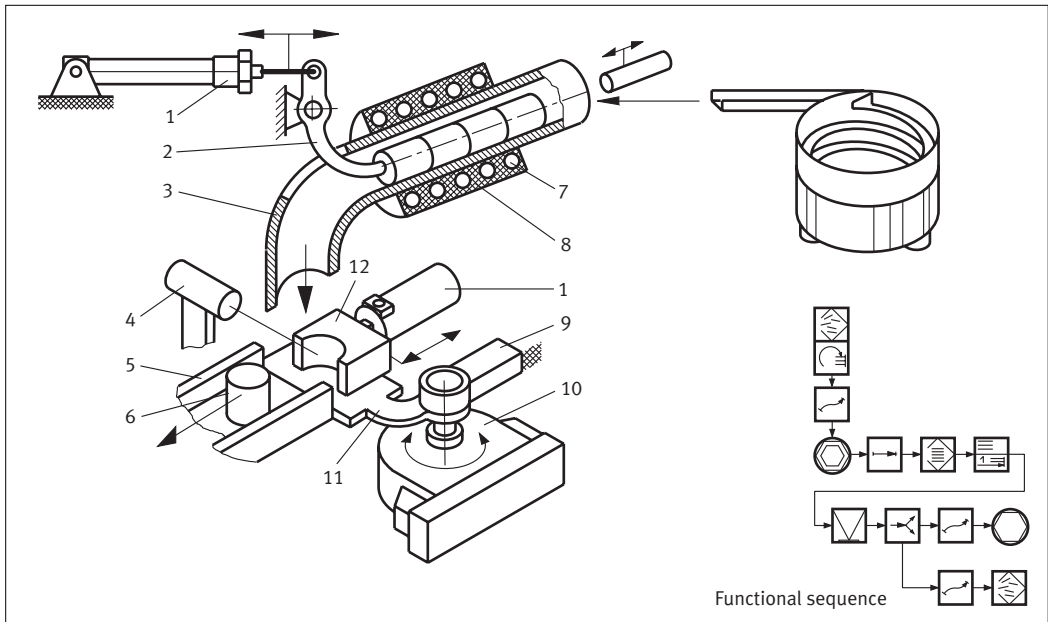

Inductive heating system

- 1 Pneumatic cylinder
- 2 Shut-off lever
- 3 Guide tube
- 4 Infrared temperature sensor
- 5 Chute
- 6 Workpiece
- 7 Inductive heating
- 8 Insulation
- 9 Fixed round guide for rotary vane
- 10 Swivel unit
- 11 Rotary vane
- 12 Slide

The purpose of the solution shown above is to feed red-hot workpieces to a machine tool such as a forging press. A minimum temperature must be ensured during this operation. The workpieces are taken from a hopper feed device and are inserted into the heating tube. Parallel to this, a workpiece is released from the other end of the tube. It falls onto the rotary vane, where its temperature is measured. In the case of workpieces which are too “cold”, the rotary vane moves away, allowing the workpiece in question to fall through. Workpieces which are at the correct temperature are pushed in a red-hot state into the machine tool (not shown) for processing. The rotary vane is mounted on special bearings which ensure that the rotary drive only needs to develop torque and does not need to compensate for any tilting forces.

Suitable components:

- Standard cylinder ESN...
- Proximity switch SM...
- Semi-rotary drive DSR...
- Standard cylinder ESW...
- Clevis foot mounting LBN...
- Rod clevis SG...
- Pneumatic single pilot valve...
- Mounting accessories
- Fittings

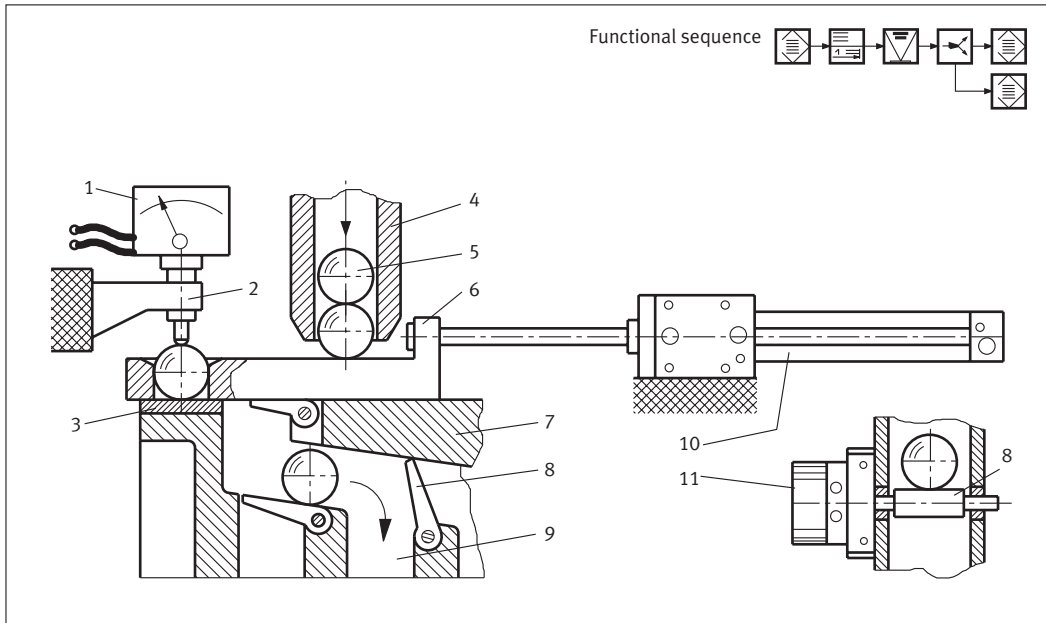

Device for checking diameter

- 1 Dial gauge
- 2 Dial gauge bracket
- 3 Hardened measurement surface
- 4 Feed tube
- 5 Workpiece (ball or roller)
- 6 Feed slide
- 7 Swivel module
- 8 Sorting flap
- 9 Sorting channel
- 10 Pneumatic cylinder
- 11 Swivel module

In a selective assembly operation, components are selected on the basis of tolerance-related compatibility and paired up. In practical terms, this means that workpieces for assembly must be pre-sorted into tolerance groups. The illustration shows a diameter testing device for rotationally symmetrical workpieces. The feed slide separates the workpieces and inserts them into the test device. The device could also be one which operates by contactless means. As the feed slide retracts, the base flap opens, allowing the test specimen in question to begin its passage through the sorting channels. Depending on the results of the measurement, one or the other sorting flap will open. The pneumatic cylinder used has an integrated guide, which means that no separate straight guide is required for the feed slide. It is also possible to use other pneumatic cylinders with non-rotating piston rods for this application.

Suitable components:

Guide unit DFP... or compact cylinder ADVULQ...
 Swivel module DSM...
 Proximity switch SM...
 Pneumatic single pilot valve...
 Fittings
 Mounting accessories

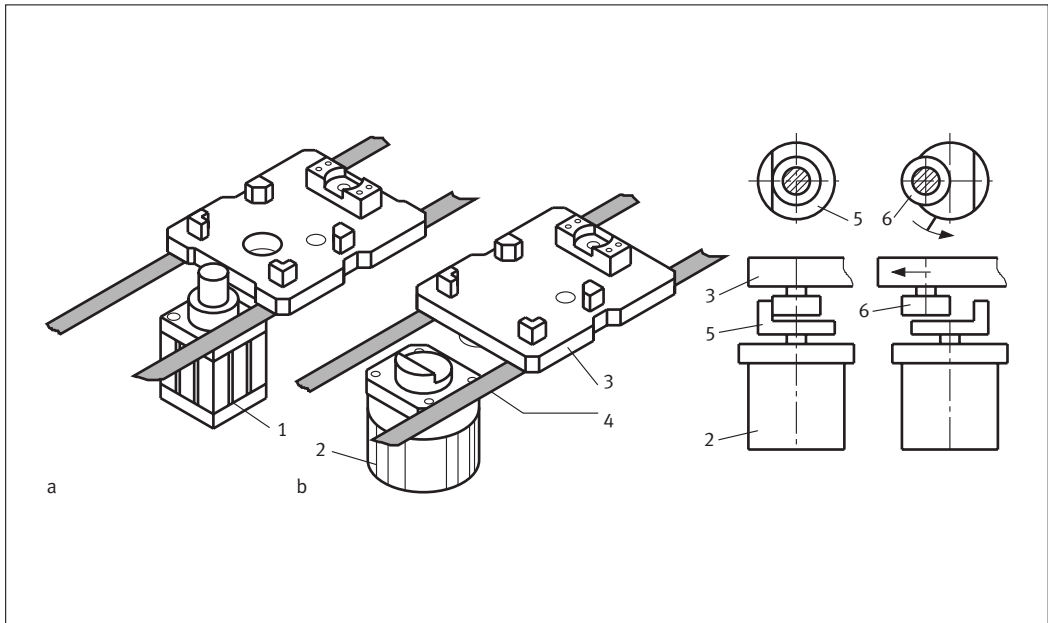

Stopping workpiece carriers

- a) Stopping with rising piston rod
- b) Stopping with rotary slide

- 1 Stopper cylinder
- 2 Rotary unit
- 3 Workpiece carrier
- 4 Twin-belt conveyor
- 5 Rotary slide
- 6 Thrust roller

In automated assembly installations, modules travel on workpiece carriers from station to station. They need to be stopped in each station and then fixed into position. The illustration shows two different stopper devices. In the case of the stopper cylinder, the reinforced piston rod advances and absorbs the entire kinetic energy. Stopping can, however, also be achieved by using a rotary slide, provided that the underside of the workpiece carriers is fitted with a thrust roller (Fig.b.). When the rotary slide is in its closed position, the roller impacts against this. In order to release the workpiece carrier, the rotary slide turns through approx. 90°. A rotary slide can, however, be used without additional support only with low-mass workpiece carriers. It is better to mount the rotary slide separately on the machine frame and to only make use of the torque of the rotary unit. The choice of stopper technology will depend on the technology and organisational method used in the installation in general. In the case of systems with thrust rollers, these rollers are of course used for other guide purposes as well and not just for stopping.

Suitable components:

- Stopper cylinder STA...
- Swivel module DSM... or DSR...
- Proximity switch SM...
- Pneumatic single pilot valve...
- Mounting accessories
- Fittings

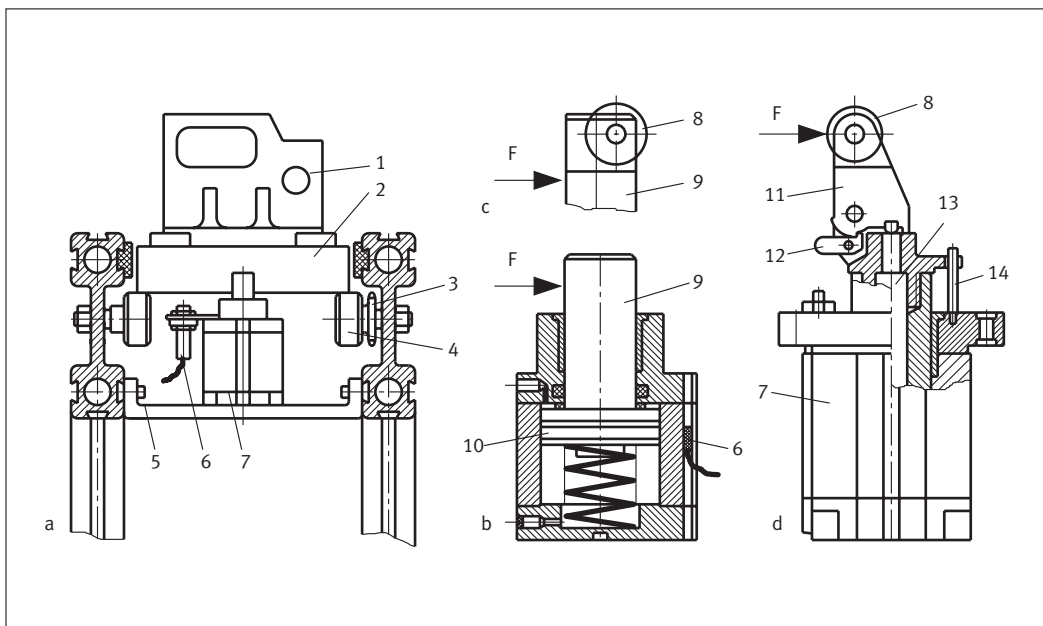

Stopping workpiece carriers

- a) Example of installation
- b) Pin version
- c) Roller version
- d) Toggle-lever version

- 1 Workpiece
- 2 Workpiece carrier
- 3 Sprocket
- 4 Support roller
- 5 Frame
- 6 Sensor
- 7 Stopper cylinder
- 8 Thrust roller
- 9 Reinforced piston rod
- 10 Piston
- 11 Toggle lever
- 12 Release lever
- 13 Hydraulic shock absorber
- 14 Protection against rotation

F Side impact force

The illustration shows a typical application of stopper cylinders. They are used to halt workpiece carriers on twin-belt transfer systems, accumulator roller conveyors, normal roller conveyors and other types of continuous conveyors. The piston rods of stopper cylinders are suitably reinforced to deal with the loads involved. The roller version makes the stopper cylinder easier to control. The piston rod can in this case advance even before the workpiece carrier has completely left the station. The end of this piston rod does not in this case rub against the underside of the workpiece carrier but "rolls" off. The roller therefore has no influence on the actual stopping operation. The toggle-lever version is more sophisticated in kinematic terms. When the workpiece carrier impacts against the roller lever, it discharges part of its kinetic energy to the integrated hydraulic shock absorber before it reaches the fixed stop. The angle lever is interlocked at this time to prevent any reactive force effects. This interlock is released when the piston of the stopper cylinder retracts. The piston rods of the cylinders are always advanced when unpressurised.

Suitable components:

- Stopper cylinder STA... Pneumatic cylinder...
- Stopper cylinder STA... R with roller Mounting accessories and fittings
- Stopper cylinder STA... K with toggle lever
- Proximity switch SM...
- Proximity sensor SIEN...

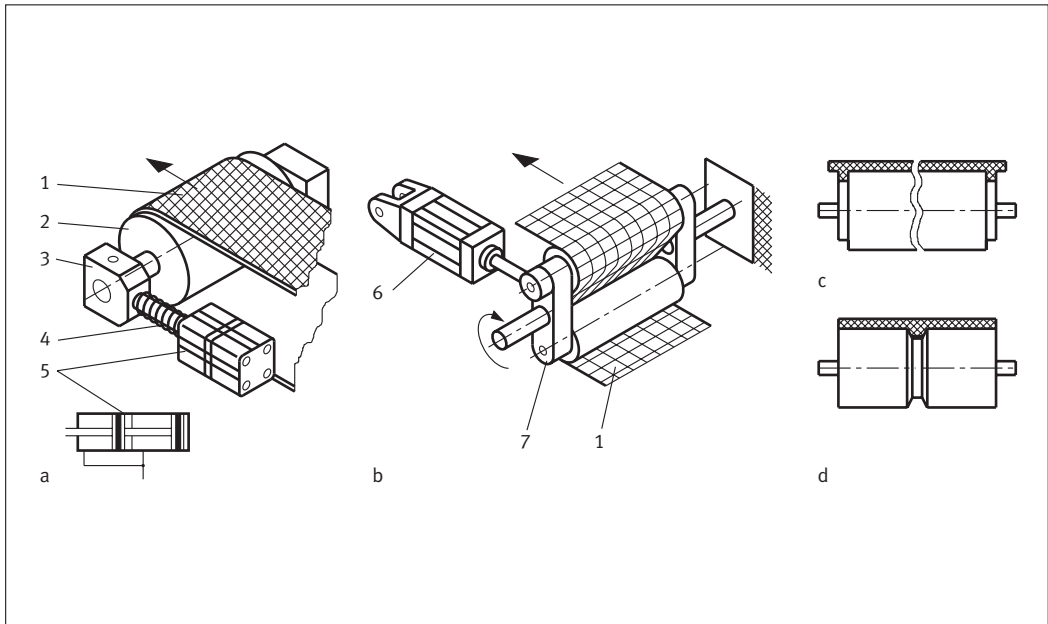

Tensioning functions on conveyor belts

- a) Belt tracking control device with adjuster roller
- b) Conveyor belt tensioner
- c) Tracking control device with belt-edge guide
- d) Tracking control device with centre-web guide

- 1 Conveyor belt
- 2 Adjuster roller
- 3 Swivel bearing
- 4 Pressure spring
- 5 Twin cylinder
- 6 Pneumatic cylinder
- 7 Roller tensioning arm

Conveyor belt systems are generally equipped with drive, guide, tensioning and adjuster rollers. For a conveyor belt to operate correctly, 2 functions must be ensured - straight tracking and precise belt tensioning. Straight tracking can be achieved by using slightly concave rollers, but a better method is to use an adjuster roller. This allows a slight pneumatic adjustment of the angle of the guide roller. An adjustment range of 20 to 40 mm will be sufficient. Mechanical edge guides can also be used as a means of ensuring straight belt tracking. With this system, the conveyor belt is provided with suitable webs at the centre of edge, as shown in Figs.c and d. There are also numerous technical solutions for belt tensioning. In the example shown, the empty side of the conveyor runs in an S shape over a pair of tensioning rollers. The required tension can be maintained consistently by varying the pressure setting. Tensioning and control functions can also be combined in a single roller configuration.

Suitable components:

Twin cylinder ADVUT...
 Pressure regulator LR...
 Proximity switch SM...
 Standard cylinder DNG... or DNC...
 Clevis foot mounting LBG...
 Rod clevis SG...
 Pneumatic single pilot valve...
 Mounting accessories, Fittings

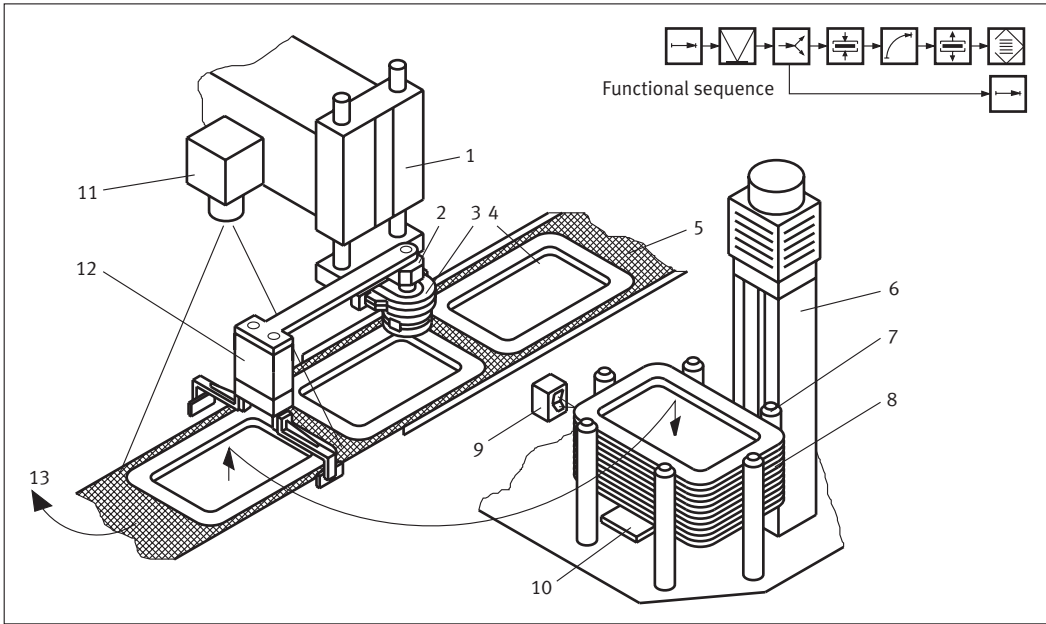

Testing and sorting station

- 1 Vertical lifting unit
- 2 Clevis foot mounting
- 3 Rotary unit
- 4 Workpiece
- 5 Conveyor belt
- 6 Spindle lifting unit
- 7 Magazine rod
- 8 Workpiece stack with tested "good" workpieces
- 9 Level sensor
- 10 Lifting arm
- 11 CCD camera with image processing software
- 12 Parallel jaw gripper
- 13 Outward transfer of defective workpieces

Flat workpieces such as food trays need to be subjected to a visual inspection after deep-drawing or screen printing to allow defective workpieces to be identified and removed. In the station shown above, this is carried out using a CCD camera. Defective workpieces are allowed to pass the camera and are eliminated downstream. Tested "good" workpieces are stacked in a magazine. The setdown height in the stack magazine is kept constant. This is controlled by an optical diffuse sensor. The workpieces are light in weight, allowing the use of grippers with a large cantilever extension.

Suitable components:

- Guided drive DFM..
- Semi-rotary drive DSR...
- Pneumatic single pilot valve...
- Parallel gripper HGP...
- Positioning axis DGE...SP
- Single-axis positioning controller EPS...
- Proximity switch SM...
- Diffuse sensor SOEG...
- Mounting accessories
- Fittings

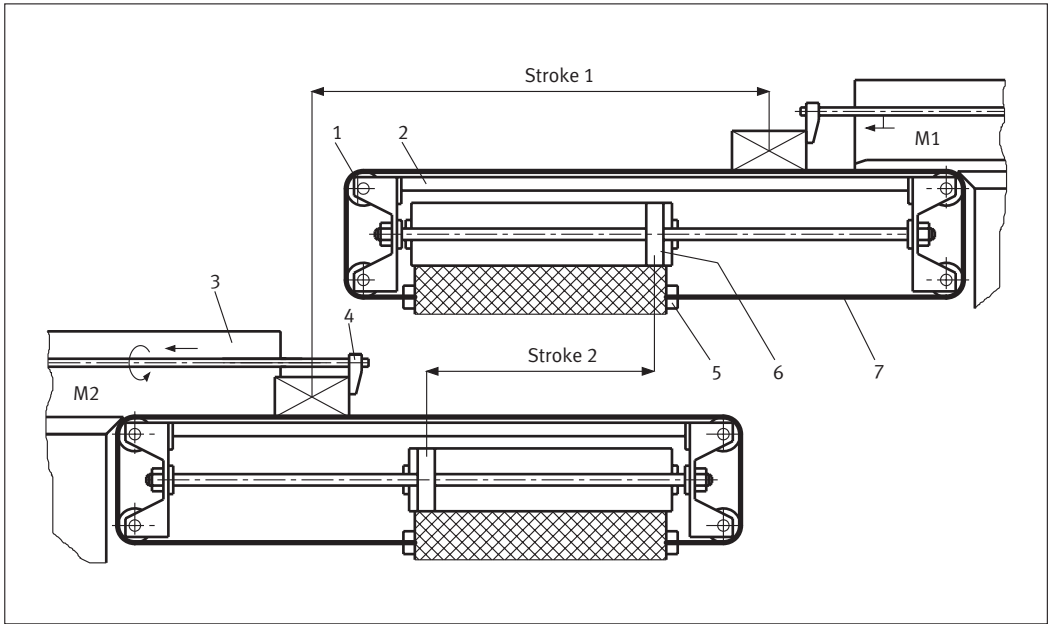

**Transfer device
with stroke doubler**

- 1 Guide roller
- 2 Connecting bridge
- 3 Destination machine
- 4 Lifting/turning slide
- 5 Clamp piece to secure plain or toothed belt
- 6 Pneumatic cylinder
- 7 Traction medium; toothed belt, plain belt, cable,

M Machine

It is frequently necessary in production processes to transfer products from point A to point B, often covering large distances. There are many ways of solving this problem. The example shows how a transfer distance can be covered by doubling the stroke of a pneumatic cylinder. The secret lies in an inversion of the principle of the loose roller. The piston travel (stroke 2) is used to derive the workpiece travel (stroke 1). The transmission belt, which runs over rollers and is secured at each end, provides a means of superimposing the motions of the cylinder piston and conveyor belt. Special devices are still required for the actual infeed and outfeed at the machine tools M1 and M2. A rodless cylinder would also be suitable for use as a drive.

Suitable components:

Standard cylinder DNC...S2 or pneumatic linear drive DGP..
 Proximity switch SM...
 One-way flow control valve GR...
 Pneumatic single pilot valve...
 Mounting accessories
 Fittings

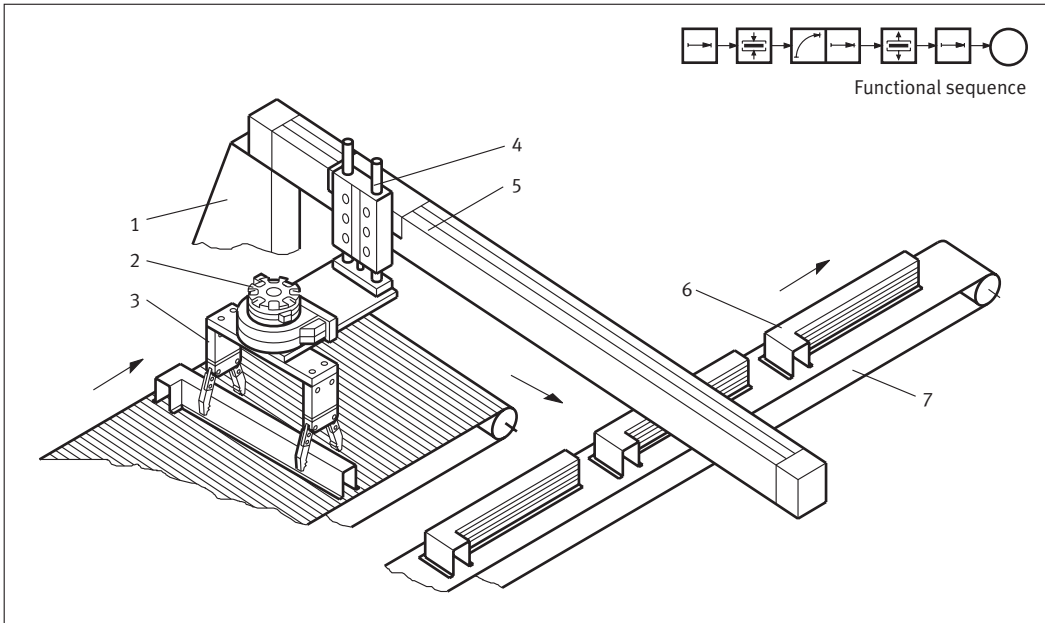

Transfer device for shaped sheet-metal workpieces

- 1 Stand
- 2 Rotary unit
- 3 Angled gripper
- 4 Lifting slide
- 5 Portal unit (rodless linear unit)
- 6 Workpiece
- 7 Conveyor belt

Shaped sheet-metal workpieces are fed outwards on a conveyor from a production line for heater components. They must then be turned through 90° for input into the next machine. When triggered by a sensor signal, the two grippers lift and turn the workpiece and lay it re-oriented on the conveyor belt, which runs at a suitably high speed. To prevent the workpieces from slipping out of the gripper, the jaws of this are rubber-covered. This also helps avoid unsightly handling marks on the sheet-metal workpieces. It would also be possible to integrate feed to a testing station or distribution to other machines into the handling operation.

Suitable components:

Rodless linear unit DGPL...
 Semi-rotary drive DSRL...
 Angled gripper HGW...
 Proximity switch SM...
 Pneumatic single pilot valve...
 Guided drive DFM...
 One-way flow control valve GR...
 Mounting accessories
 Fittings

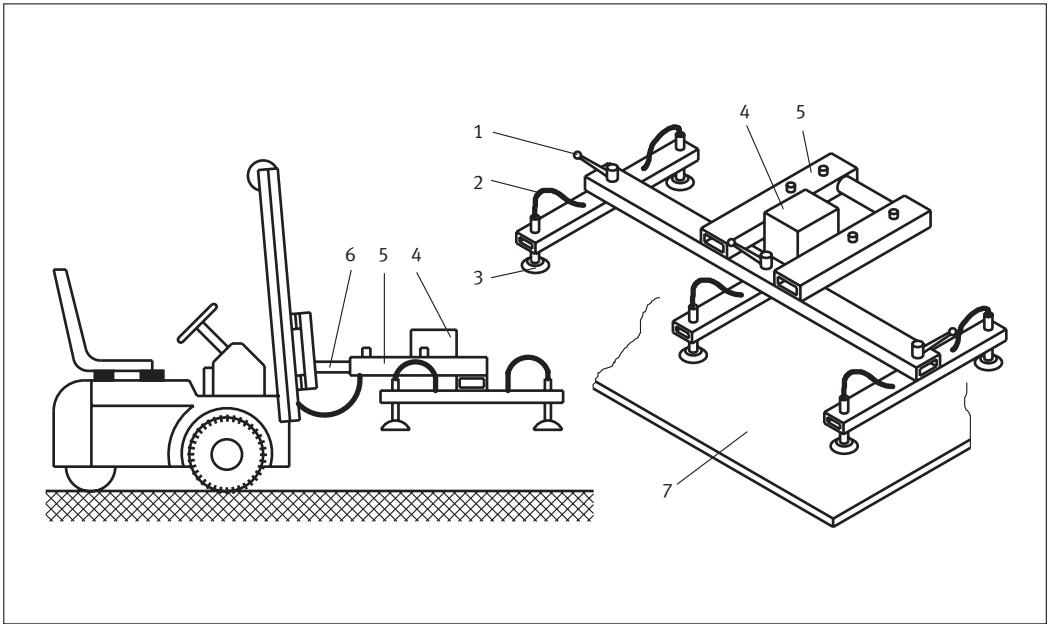

Vacuum lifting device for panels

- 1 Clamp lever for arm adjustment
- 2 Vacuum tubing
- 3 Round or oval suction cups
- 4 Vacuum pump and vacuum reservoir
- 5 Mounting frame made of square tubing
- 6 Lifting fork
- 7 Material to be handled

Large panel material can only be transported by either several persons or a lifting device of some kind. But this need not be a conventional hoist. The suction-cup “spider” shown above is used to transport panels weighing up to 250 kg, which may be made of sheet metal, plastic or chipboard. In the case of very thin panels, a larger number of suction cups should be used to avoid the danger of distortion. The individual suction cups are adjustable in several directions. They should also be ball-joint-mounted to allow a slight movement, since sheet metal panels will always sag somewhat when picked up. The special feature of this solution is the mounting frame made of square tubing, which allows the vacuum lifting device to be fitted rapidly to the lifting fork of a fork-lift truck. This solution greatly simplifies the transportation of panel material within factories and reduces the risk of accidents. It does not impede the use of the fork-lift truck for normal purposes. The mounting frame is equipped with a small vacuum pump and vacuum reservoir.

Suitable components:

Suction cup VAS...
 Vacuum pump...
 Vacuum efficiency valve ISV...
 Height compensator VAL...
 Vacuum accessories
 Mounting accessories
 Fittings

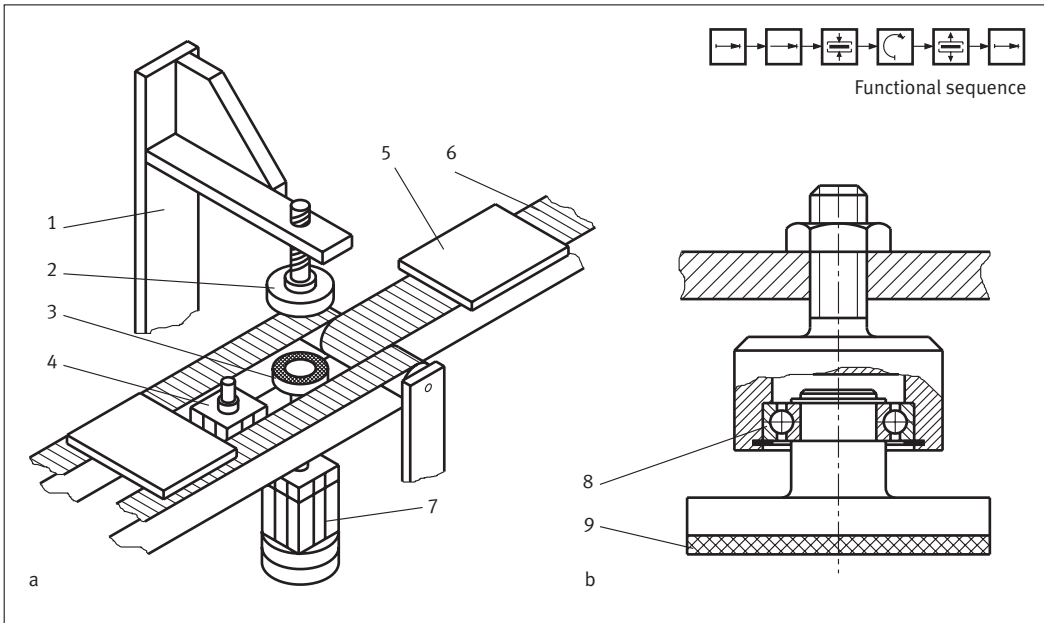

**Turning station
within a transfer line**

- a) View of station
- b) Design of counter-support

- 1 Frame
- 2 Rotary plate
- 3 Lifting/rotating plate
- 4 Stopper cylinder
- 5 Working material (workpiece carrier)
- 6 Conveyor belt
- 7 Swivel/linear unit
- 8 Ball bearing
- 9 Rubber support

It is frequently necessary for technological reasons during the processing of panel material to turn this through 90°, and sometimes through 180°. The solution shown here slightly lifts the workpiece to be turned in the vicinity of its centre of gravity and clamps it against a ball bearing mounted rotary plate. The workpiece is then turned and set down on the adjoining conveyor belt. A stopper cylinder acts as a stop as the workpiece enters the turning station. This cylinder should be adjustable for different workpiece sizes. An alternative solution would be a ball castor table as a support with a swivel/linear unit above this. The panel would then be pressed from above against the ball castors and turned. Since the turning motion is achieved through a force-locking connection, the coefficient of friction between the panel and plate must be sufficiently high.

Suitable components:

- Swivel/linear unit DSL...
- Stopper cylinder STA...
- Pneumatic single pilot valve VL...
- Proximity switch SM...
- Mounting accessories
- Fittings

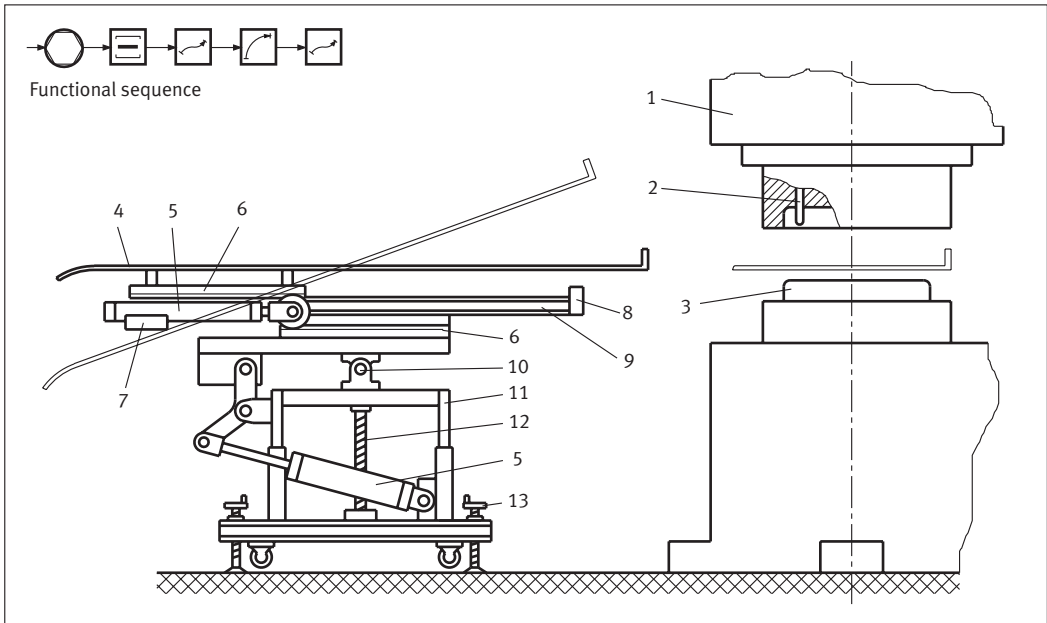

Output device for large formed sheet-metal workpieces

- 1 Press ram
- 2 Ejector pin
- 3 Lower half of tool, e.g. drawing tool
- 4 Ejector table
- 5 Pneumatic cylinder
- 6 Gear rack
- 7 Mounting
- 8 Stop
- 9 Straight guide
- 10 Rotary joint
- 11 Lifting frame
- 12 Adjustment spindle
- 13 Locking device

Shaped sheet-metal workpieces must be removed from the working area of a press as quickly as possible in order to achieve a fast working cycle. The device shown above advances a platform after the press tool opens. The shaped sheet-metal workpiece released by the ejectors in the upper part of the press tool then falls onto this platform. The platform then retracts and is tilted in its end position. The workpiece can now slide away. In order to allow the platform to be inserted deep into the press working area, its working stroke is doubled by means of a rack-and-pinion mechanism. Other solutions would also be possible, for example using a rodless guide unit. The output device is fitted with castors and can be moved for use with various different presses. There are of course also two-axis unloading robots that can be fitted to presses. These pick up shaped sheet-metal workpieces using mechanical grippers or suction cups. The question of which solution is better will depend on specific operating conditions.

Suitable components:

Standard cylinder DNC...
 Swivel flange SNCS...
 Proximity switch SM...
 Pneumatic single pilot valve VL...
 Rod clevis SG...
 Mounting accessories
 Fittings

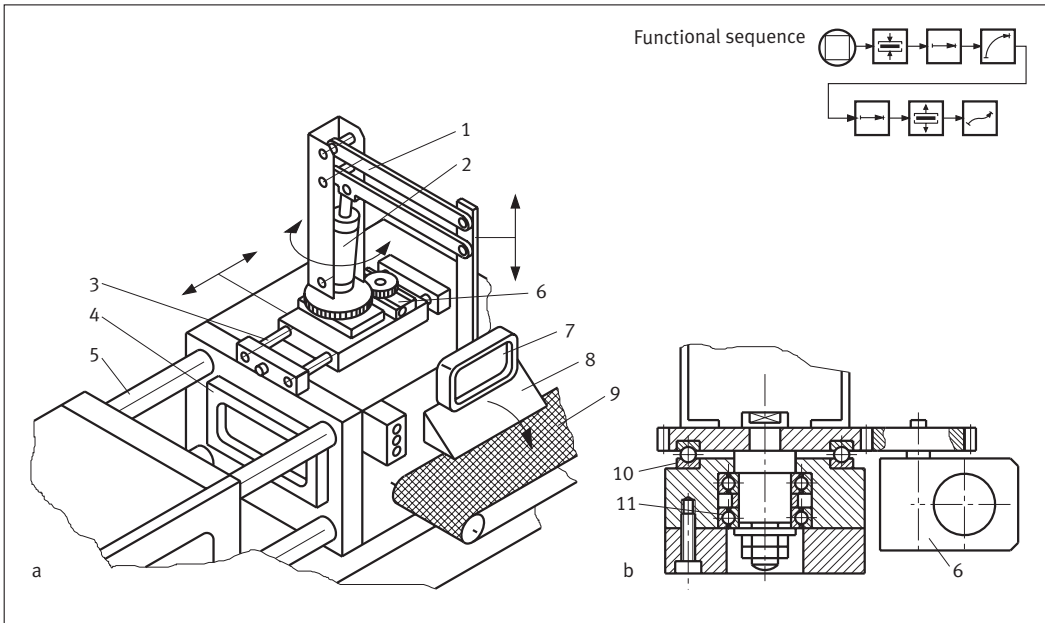

Removal device for injection mouldings

a) Overall configuration b) Pivot bearing

- 1 Parallelogram arm
- 2 Pneumatic cylinder
- 3 Linear unit for removal stroke
- 4 Injection mould
- 5 Spar
- 6 Rotary unit
- 7 Injection moulding
- 8 Guide plate
- 9 Outfeed conveyor belt
- 10 Pressure bearing
- 11 Pivot axis

There are two types of operations associated with injection moulding machines which should be carried out automatically if at all possible. These are the fitting of inserts to tools, in an action similar to an assembly operation, and the removal of finished workpieces. Particularly for the latter operation, simple handling devices of the “pick-and-place” type are more than adequate. These devices can be formed by combining linear units with suitable strokes. It is, however, also possible to use rotary units, as shown in the illustration above. After the tool has opened, the moulding is accessible and can be picked up with a suction cup or mechanical gripper. The articulated arm is mounted in a bearing at its base in such way that the rotary unit can apply only torque and no axial or tilting forces. Axis 1 provides the removal stroke.

Suitable components:

Rotary drive DRQ...
 Angle gripper HGW... or suction cup VAS...
 Linear unit SLZ...
 Pneumatic single pilot valve VL...
 Proximity switch SM...or SME/SMT...
 Standard cylinder DNG...
 Swivel flange SSNG...
 Rod clevis SG...

Further literature

Deppert, W.; Stoll, K.: Pneumatikanwendungen – Kosten senken mit Pneumatik (Pneumatic Applications - Cutting Costs With Pneumatics), published by Vogel Verlag, Würzburg 1990

Deppert, W.; Stoll, K.: Pneumatische Steuerungen (Pneumatic Control Systems), published by Vogel Verlag, Würzburg 1994

Hesse, S.: Gripperanwendungen (Grippers And Their Applications), in the series “Blue Digest On Automation”, published by FESTO, Esslingen 1997

Hesse, S.: Praxiswissen Handhabungstechnik in 36 Lektionen (Practical Handling Technology In 36 Lessons), published by expert Verlag, Renningen 1996

Hesse, S.: Spannen mit Druckluft und Vakuum (Clamping With Compressed Air And Vacuum), in the series “Blue Digest On Automation”, published by FESTO, Esslingen 1999

Hesse, S.: Lexikon Handhabungseinrichtungen und Industrierobotik (Lexicon Of Handling Devices And Industrial Robotics), published by expert Verlag, Renningen 1995

Hesse, S.: Gripper – Praxis (Grippers in Practice), published by Vogel Verlag, Würzburg 1991

Hesse, S.; Nörthemann, K.-H.; Krahn, H.; Strzys, P.: Vorrichtungen für die Montage (Assembly Equipment), published by expert Verlag, Renningen 1997

Hoffman, E.; Stein, R.: Pneumatik in der Konstruktion (Pneumatics For Designers), published by Vogel Verlag, Würzburg 1987

Lotter, B.: Manufacturing Assembly Handbook, in the series “Blue Digest On Automation”, published by FESTO, Esslingen 1986

Steinsiek, E.: Zuführungssysteme zur Fertigungsautomatisierung – Handlungsanleitung (Feed Systems for Production Automation – A Practical Guide), published by Verlag TÜV Rheinland, Cologne 1989

A	Accumulator conveyor	34
	Accumulator conveyor length	33
	Adhesive applicator device	61
	Adjuster roller	107
	Air barrier	79
	Alignment mechanism	16
	Alternate feeding	49
	Assembly platform	20
	Assembly press	87
	Assembly station	17, 20, 21
	Assembly transfer installation	22
	Assembly unit	73
B	Balancer	72
	Basic grippers	62
	Bellows suction cup	65
	Belt tracking control	107
	Bending tool	23
	Bottle re-positioning device	94
	Brazing station	48
	Buffer unit	25
	Bulk-material hopper	68
C	CCD camera	108
	Centring mandrel	17
	Centring cylinder	20
	Chamfering pipe ends	27
	Checking diameter	104
	Checking workpiece position	77
	Circlips	19
	Clamping device	29
	Clamp arm	28
	Clamp force flow	30
	Clamp jaws	63
	Clamp sleeve	85
	Clothes press	88
	Controler drum	69
	Conveyor belt tensioner	107
	Cross-slide unit	84
	Cutter unit	101
	Cutter wheel	102
D	Deburring press	37
	Degree of automation	11
	Destacking device	39
	Device to re-position sheet glass	95
	Diaphragm pressure	36
	Diaphragm clamping module	29

	Disc suction cups	65
	Distributor	75
	Double arm	40
	Double clamping device	28
	Doubling the stroke	109
	Drill bit breakage monitoring	76
	Drilling station	44
	Drilling device	43, 45
	Drum magazine	24
E	End-position monitoring	77
F	Feed	37
	Feed conveyor belt	81
	Feeding a press	50
	Feed magazine	55
	Feed slide	57, 91
	Feed unit	36
	Filling station	94
	Flexibility	11
	Fluidic muscle	64, 71, 87
	Forwarding device	60
	Four-finger gripper	63
	Four-link mechanism	96
	Freewheel unit	70
G	Gripper for removal of sheet metal workpiece	63
H	Handling symbols	14
	Hexapod design	66, 92
	High-power collect chucks	42
	Hinged presses	88
	Hold-back arm	56
	Hopper feed device	103
	Hopper orientation device	80
I	Indexing	69
	Indexing chain system	60
	Indexing disc	100
	Inductive heating system	103
	Interference barrier sensor	80
	Intermediate buffer	24
J	Jaw-type gripper	64
L	Lateral cut-off device	101
	Leg construction	92
	Lever ejector	47
	Lifting rack system	60

	Lifting unit	72
	Lifting units	71
	Lift-up safety guard	99
	Lift-up door	99
	Linking	73
	Link mechanism	88
	Loading table	54
	Loading tables	75
	Longitudinal pressing	85, 89
M	Magazine	57, 93
	Magazine tube	21
	Magazine feed	51, 55
	Malfunction buffers	25
	Miniature pick-and-place unit	18
	Miss-alignment	79
	Multiple gripper	82
	Multiple clamping systems	31
	Multiple workpiece clamps	42
	Monitoring of presence	76
	Movable detent	60
O	Orientation operation	78
	Orientation rotor	78
	Oscillating-lever ejector	46
	Output device	113
P	Packing	81
	Pallet	82
	Palleting system	82
	Palleting pattern	82
	Parallel-jaw gripper	62
	Parallelogram arms	72
	Pick-and-place unit	66
	Pin magazine	70
	Pneumatic chuck	41
	Pneumatic die-cushion	38
	Pneumatic pressure conveyor system	35
	Positioning gear	15
	Positioning unit	83
	Presence sensor	77
	Press	38, 86
	Press-fitting unit	87
	Pressure booster	89
	Pressure vessel lock	35

R	Removal device	114
	Re-orientating	93
	Re-positioning device	95
	Roller conveyor magazine	43
	Roller pressure device	44
	Roller conveyor	33
	Roller feed device	53
	Rotary feeder	40
	Rotary feed device	26
	Rotary magazine	24
	Stop lever	58
	Swing saw for round timber	97
	Slipping clutch	34
S	Safety circuit	99
	Safety guards	99
	Saw unit	98
	Scoop	55, 80
	Self propelled machine	92
	Semi-rotary drives	83
	Sensor valves	34
	Separation	58
	Shear bolt sensors	68
	Sheet-glass trolley	95
	Shut-off device	35
	Slide ejector	46
	Sliding grill	99
	Sliding magazine	24
	Small press	89
	Sorting station	108
	Special drilling unit	41
	Special gripper	64
	Spindle clamp	80
	Spreader magnet	54
	Stack magazine	26, 55, 58, 108
	Stop system	15
	Stopper cylinder	100, 106
	Stopper devices	105
	Strip magazine	91
	Suction-cup spider	110
	Suction extractor arms	48
	Suction plate	50
	Swing saw	97
	Swivel arm	50
	Swivel arm pick-and-place device	67
	Swivel feed device	59
	Swivel/linear unit	65

T	Tampon printing method	90
	Testing device	104
	Thread rolling	52
	Tin-can transferring device	96
	Toggle-lever clamping	45
	Toggle-lever clamping system	32
	Tool breakage monitoring	76
	Traction unit	95
	Tracking press	88
	Transfer device	109, 110
	Transfer line	22
	Transfer unit	73
	Transmission lock	100
	Turning station	112
	Turnover vane	93
	Twin-arm assembly device	18
	Twin-arm mini handling device	18
	Twin stack lifting unit	40
	Two-handed safety start block	89
V	Vacuum lifting device	111
	V-clamp	43
	V-jaws	62
W	Wall gantries	84
	Waste material cutter	36
	Wedge shaped cut	102
	Workpiece orientation	80
	Workpiece carrier	21, 22, 105
	Workpiece carrier magazine	69